

# **C7-SUB**

## **Manual (3.0E)**

## References in the manual

### **WARNING!**

This refers to a potentially dangerous situation which may lead to personal injury.

### **CAUTION!**

This refers to a potentially dangerous situation which may lead to damage to the equipment.

### **IMPORTANT!**

This refers to a situation which may cause the equipment to malfunction.

## Symbols on the equipment



Please refer to the information in the operating manual.



**WARNING!**  
**Dangerous voltage!**

## General Information

C7-SUB Manual

Version 3.0E, 10/2003, D2080.E.03

© by d&b audiotechnik AG 2003; all rights reserved.

The information contained in this manual has been carefully checked for accuracy, at the time of going to press, however no guarantee is given with respect to the correctness.

d&b audiotechnik AG accepts no responsibility for any errors or inaccuracies that may appear in this manual or the products and software described in it.

Technical specifications, dimensions, weights and properties do not represent guaranteed qualities.

As manufacturers we reserve the right to make alterations and modifications within the framework of legal provisions, as well as changes aimed at improving quality.

d&b audiotechnik AG

Eugen-Adolff-Strasse 134, D-71522 Backnang, Germany

Telephone +49-7191-9669-0, Fax +49-7191-95 00 00

E-mail: docadmin@dbaudio.com, Internet: www.dbaudio.com

## Safety precautions

**Before you use our products, read the manual carefully and observe all the safety precautions. They will protect you and help to avoid equipment failures.**

**Keep this manual in a safe place so that it is available for future reference.**

**If you supply d&b products, please draw the attention of your customers to these safety guidelines. Enclose the relevant manuals with the systems. If you require additional manuals for this purpose, you can order them from d&b.**

### Information regarding use of loudspeakers

#### **WARNING!**

Never stand in the immediate vicinity of loudspeakers driven at a high level. Professional loudspeaker systems are capable of causing a sound pressure level detrimental to human health. Seemingly non-critical sound levels (from approx. 95 dB SPL) can cause hearing damage if people are exposed to it over a long period.

In order to prevent accidents when deploying loudspeakers on the ground or when flown, please take note of the following:

When setting up the loudspeakers or loudspeaker stands, make sure they are standing on a firm surface. If you place several systems on top of one another, use straps to secure them against movement.

Only use accessories which have been tested and approved by d&b for assembly and mobile deployment. Pay attention to the correct application and maximum load capacity of the accessories as detailed in our specific "Mounting instructions" or in our "Flying system and Rigging manuals".

Ensure that all additional hardware, fixings and fasteners used for installation or mobile deployment are of an appropriate size and load safety factor. Pay attention to the manufacturers instructions and to the relevant safety guidelines.

Regularly check the loudspeaker housings and accessories for visible signs of wear and tear, and replace them when necessary.

Regularly check all load bearing bolts in the mounting devices.

#### **CAUTION!**

Loudspeakers produce a static magnetic field even if they are not connected or are not in use. Therefore make sure when erecting and transporting loudspeakers that they are nowhere near equipment and objects which may be impaired or damaged by an external magnetic field. Generally speaking, a distance of 0.5 m (1.5 ft) from magnetic data carriers (floppy disks, audio and video tapes, bank cards, etc.) is sufficient; a distance of more than 1 m (3 ft) may be necessary with computer and video monitors.

## C7-SUB

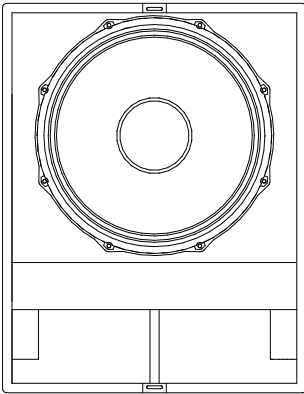

### CAUTION!

The C7-SUB is a bass-reflex design employing a long excursion 18" driver. The large, specially shaped reflex port enables the C7-SUB to achieve high sound pressure levels with minimal power compression and breathing effects.

The C7-SUB cabinet is constructed from marine plywood and has an impact resistant paint finish. The front of the loudspeaker cabinet is fitted with a rigid metal grill covered with a replaceable acoustically transparent foam, and fitted with catches to the top and bottom for securing an optional transport lid E7916. The cabinet incorporates two steel handles, four M10 threaded inserts for attaching installation hardware and four heavy duty wheels. An M20 threaded flange in the top panel accepts the d&b Z5013 Loudspeaker stand for the deployment of full range cabinets.

Only operate C7-SUB cabinet with a d&b D12 or E-PAC amplifier in C7-SUB mode or a P1200A mainframe fitted with a C7-SUB controller module, otherwise there is a risk of damaging the loudspeaker components.

### Connections

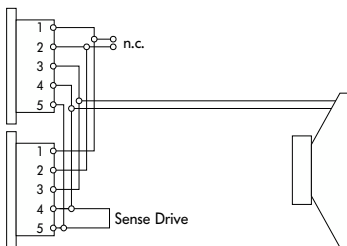

**Connector wiring**

The C7-SUB cabinet is fitted with a pair of EP5 connectors. All pins of both connectors are wired in parallel.

The C7-SUB uses the pin assignments 3/4 and 5 (Pin 5: SenseDrive - D12 only and in conjunction with 5-wire cables). Pins 1/2 are designated to d&b full range systems.

Using one connector as the input, the second connector allows for direct connection to additional cabinets.

The C7-SUB can be supplied with NL4 output connectors as an option using the pin assignment 2+/2-. Pins 1+/1- are designated to d&b full range systems.

Pin equivalents of EP5 and NL4 connectors are listed in the table below.

<b>EP5</b>	1	2	3	4	5 (SenseDrive SUB)
<b>NL4</b>	1+	1-	2+	2-	n.c.

**EP5 and NL4 pin assignments**

## Operation with D12

Selecting C7-SUB mode in the D12 enables up to two C7-SUB cabinets to be driven by each channel. In applications with low continuous levels and low ambient temperatures up to three cabinets per channel may be connected.

When the D12 is operated in "Mix TOP/SUB" mode C7-SUB cabinet and a respective full range system can be linked together locally and fed by a single 4-wire cable from either amplifier output connector.

## IMPORTANT!

To apply SenseDrive for the subwoofer, EP5 connectors and 5-wire cables have to be used. When operated in "Mix TOP/SUB" mode the subwoofer has to be fed from the output B connector of the D12 amplifier.

### Controller settings

For acoustic adjustment the 100 Hz setting can be selected.

#### 100 Hz

If the 100 Hz setting is selected, the upper operating frequency of the system is reduced from 140 Hz to 100 Hz. This setting allows the C7-SUB to supplement TOP cabinets in full range mode (i.e. CUT not selected).

The 100 Hz setting may also be used with TOP cabinets in CUT mode to compensate for room resonances often found in the 125 Hz band.

## Operation with E-PAC (Version 3 with display only)

Selecting C7-SUB mode in the E-PAC enables one C7-SUB cabinet to be driven at an output power of 300 Watts. We do not recommend that two C7-SUB cabinets are driven in LO IMP mode as the 6 dB reduction in input level to the loudspeakers results in no gain in acoustical output.

The 100 Hz setting is available. The characteristics of the 100 Hz setting is explained under the previous section "Operation with D12 - Controller settings".

## Operation with P1200A

Up to two C7-SUB cabinets can be driven by each P1200A power amplifier channel fitted with a C7-SUB controller module. Fitting one C7-SUB and one TOP controller module allows a single mainframe to drive two C7-SUB and two TOP cabinets. All cabinets can be linked together locally and fed by a single 4-wire cable from either mainframe output connector.

The 100 Hz setting is available. The characteristics of the 100 Hz setting is explained under the previous section "Operation with D12 - Controller settings".

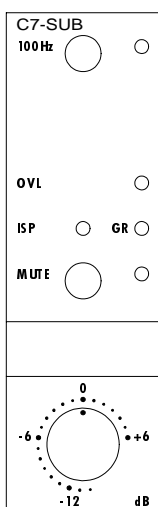

Controls on C7-SUB controller module

## Technical specifications

### C7-SUB system data

Frequency response (-5 dB).....	44 Hz - 140 / 100 Hz
Max. sound pressure (1 m, free field) with D12.....	135 dB
Max. sound pressure (1 m, free field) with E-PAC .....	131 dB
Max. sound pressure (1 m, free field) with P1200A.....	133 dB
	(SPLmax peak, pink noise test signal with crest factor of 4)
Input level (100 dB SPL / 1m) .....	-13 dBu
Polarity to controller INPUT (XLR pin 2: + / 3: -) .....	LF: +

### C7-SUB subwoofer

Nominal impedance .....	8 ohms
Power handling capacity (RMS / peak 10 ms).....	400 / 1200 W
Connections .....	2 x EP5
Pin assignments .....	3/4 and 5 (Pin 5: SenseDrive - D12)
optional.....	2 x NL4
Pin assignments .....	2+ / 2-
Weight .....	49 kg (108 lb)

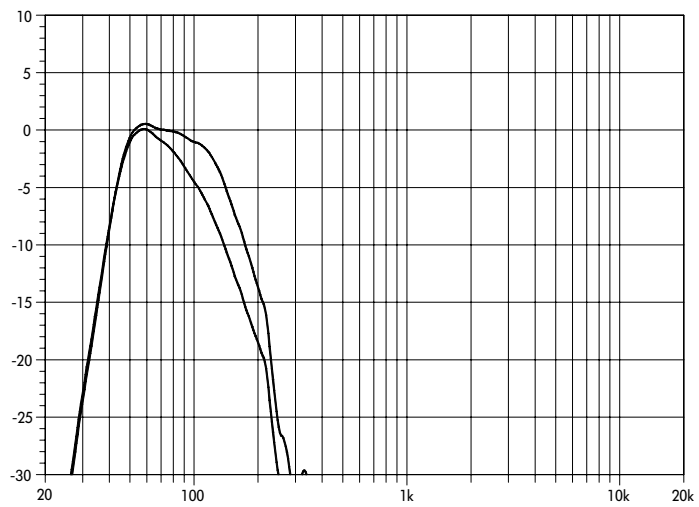

**C7-SUB frequency response, standard and 100 Hz settings**

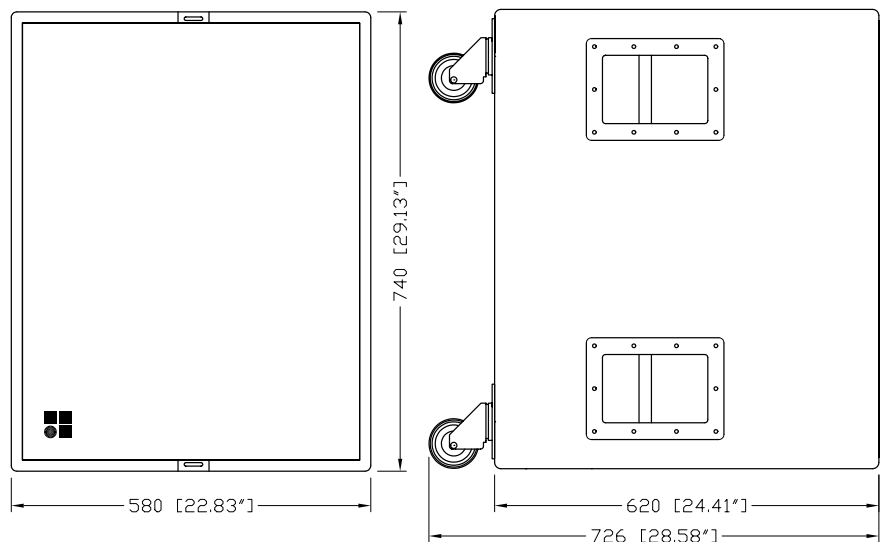

**C7-SUB cabinet dimensions in mm [inch]**

## EU declaration of conformity (CE symbol)



### EU conformity of loudspeakers

This declaration applies to loudspeakers manufactured by d&b audiotechnik AG and includes the types listed in the table below:

- **C7-SUB Z2259**

All production versions of these types are included, provided they correspond to the original technical version and have not been subject to any later design or electromechanical modifications.

**We herewith declare that said products are in conformity with the provisions of the following EC directives including all applicable amendments:**

- **89/336 Electromagnetic Compatibility**

**The following standards have been applied:**

- **DIN EN 55013:08-1991**
- **DIN EN 55020:05-1995**
- **DIN EN 50082-1:03-1993**

