

# XS

**18S/18A-SUB**  
**Manual 1.5 en**

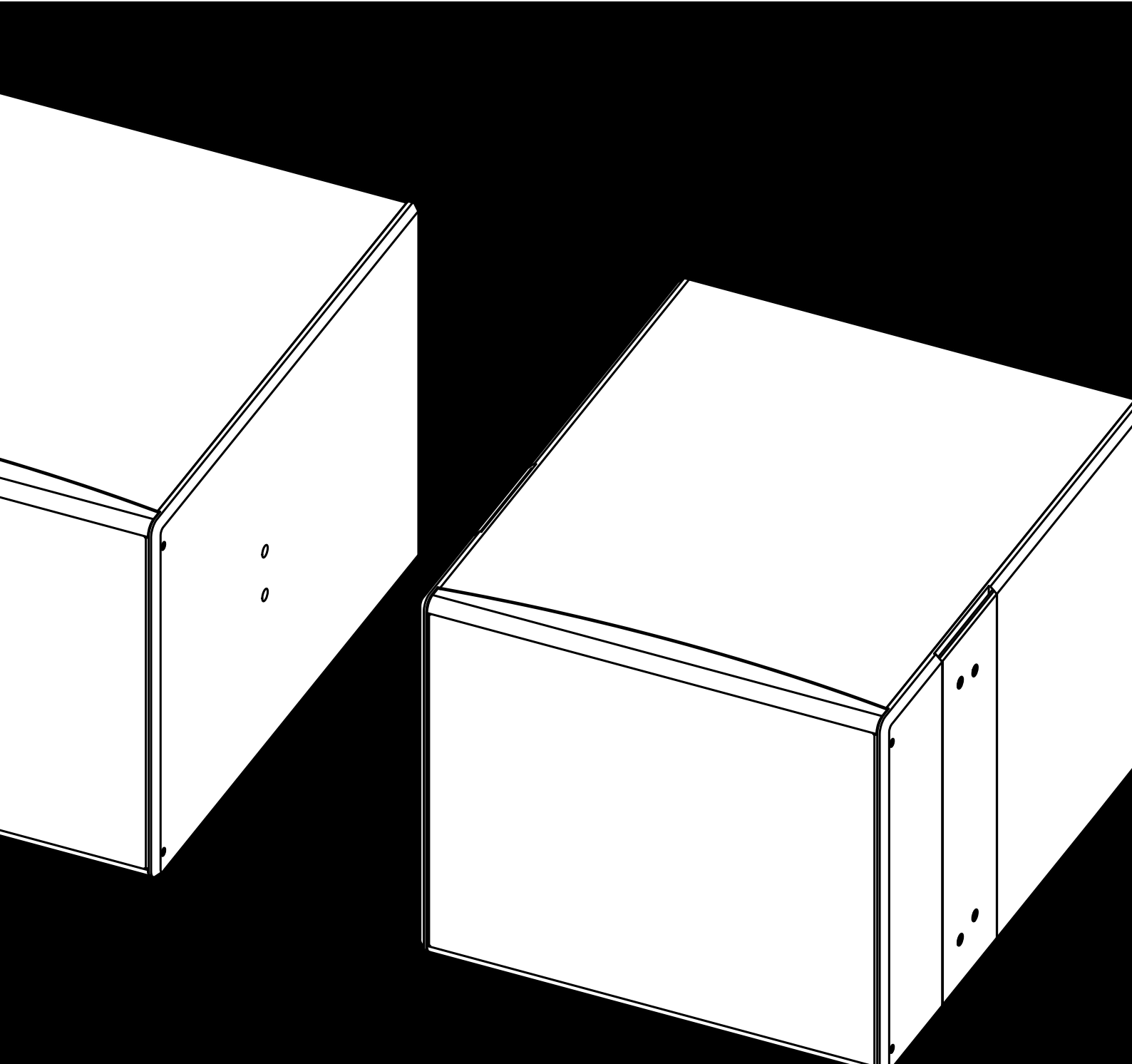

## **General information**

18S/18A-SUB Manual

Version: 1.5 en, 10/2016, D2613.EN .01

Copyright © 2016 by d&b audiotechnik GmbH; all rights reserved.

**Keep this manual with the product or in a safe place so that it is available for future reference.**

When reselling this product, hand over this manual to the new owner.

d&b audiotechnik GmbH  
Eugen-Adolff-Strasse 134, D-71522 Backnang, Germany  
T +49-7191-9669-0, F +49-7191-95 00 00  
docadmin@dbaudio.com, www.dbaudio.com

<b>1. Safety precautions</b> .....	<b>4</b>
1.1. Information regarding the use of loudspeakers.....	4
<b>2. 18S-SUB/18A-SUB loudspeaker</b> .....	<b>5</b>
2.1. Product description.....	5
2.2. Connections.....	6
2.3. Operation.....	7
2.3.1. Controller settings.....	7
2.4. Technical specifications.....	8
<b>3. Manufacturer's Declarations</b> .....	<b>9</b>
3.1. EU conformity of loudspeakers (CE symbol).....	9
3.2. WEEE Declaration (Disposal).....	9

## 1.1. Information regarding the use of loudspeakers

### Potential risk of personal injury

Never stand in the immediate vicinity of loudspeakers driven at a high level. Professional loudspeaker systems are capable of causing a sound pressure level detrimental to human health. Seemingly non-critical sound levels (from approx. 95 dB SPL) can cause hearing damage if people are exposed to it over a long period.

In order to prevent accidents when deploying loudspeakers on the ground or when flown, please take note of the following:

- When setting up the loudspeakers or loudspeaker stands, make sure they are standing on a firm surface. If you place several systems on top of one another, use straps to secure them against movement.
- Only use accessories which have been tested and approved by d&b for assembly and mobile deployment. Pay attention to the correct application and maximum load capacity of the accessories as detailed in our specific "Mounting instructions" or in our "Flying system and Rigging manuals".
- Ensure that all additional hardware, fixings and fasteners used for installation or mobile deployment are of an appropriate size and load safety factor. Pay attention to the manufacturers' instructions and to the relevant safety guidelines.
- Regularly check the loudspeaker housings and accessories for visible signs of wear and tear, and replace them when necessary.
- Regularly check all load bearing bolts in the mounting devices.

### Potential risk of material damage

Loudspeakers produce a static magnetic field even if they are not connected or are not in use. Therefore make sure when erecting and transporting loudspeakers that they are nowhere near equipment and objects which may be impaired or damaged by an external magnetic field. Generally speaking, a distance of 0.5 m (1.5 ft) from magnetic data carriers (floppy disks, audio and video tapes, bank cards, etc.) is sufficient; a distance of more than 1 m (3 ft) may be necessary with computer and video monitors.

## 2. 18S-SUB/18A-SUB loudspeaker

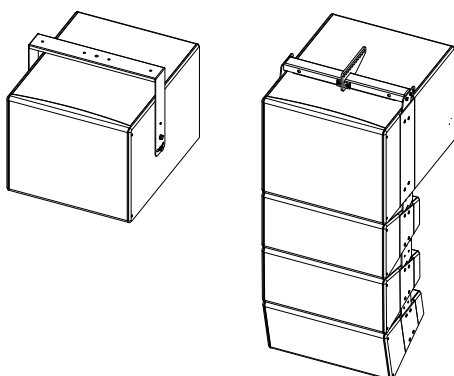
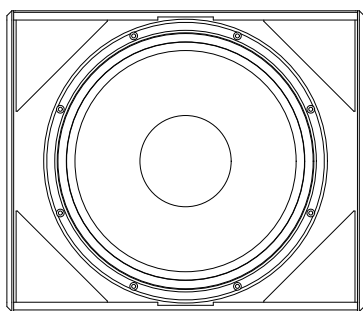

**Fig. 1: 18S-SUB/18A-SUB loudspeaker**

**Rigging examples:**

18S-SUB ceiling mounted with Z5410 Horizontal bracket 18S/27S.  
10AL/18A-SUB array.

### 2.1. Product description

The 18S-SUB and 18A-SUB are compact high performance subwoofers for use with d&b xS-Series and xA-Series loudspeakers. The cabinets house a long excursion 18" neodymium driver in a bass-reflex design.

The 18A-SUB incorporates the same acoustic components as the 18S-SUB, however, the cabinet is equipped with an integrated rigging system for the design of vertical arrays. The 18A-SUB can be combined with 10A and 10AL loudspeakers.

The frequency response extends from 37 Hz to 140/100 Hz.

The enclosures are constructed from marine plywood with an impact resistant black paint finish. The fronts of the cabinets are protected by a rigid metal grill backed by an acoustically transparent foam.

The 18S-SUB is equipped with four rubber feet to prevent cabinet movement and protect the bottom panel against scratching.

The cabinets are Ball Impact Resistant according to DIN 18032-3.

### 18S-SUB rigging components

The 18S-SUB side panels are each equipped with a pair of M10 threads to accept the Z5410 Horizontal bracket 18S/27S. The threaded inserts are covered by dummy caps in cabinet color. The caps must be removed before mounting any accessories.

### 18A-SUB rigging components

18A-SUB cabinets are connected to form a vertical array each using the Z5418 Connector plates xA-SUB. Up to four 18A-SUB cabinets can be connected. When integrated at the top of a 10A or 10AL array, up to two 18A-SUB cabinets can be combined with up to six 10A/10AL cabinets.

Vertical arrays are supported using the Z5414 Flying bar xA and the Z5413 Flying bar connector plates xA. For approved configurations as well as safety and mounting instructions, refer to the respective rigging manual.

### Cabinet options

The weather resistant version (WR) is suitable for outdoor use (IP34, vertical aiming up to 0°). The cabinets have an impact and weather protected black PCP (Polyurea Cabinet Protection) finish.

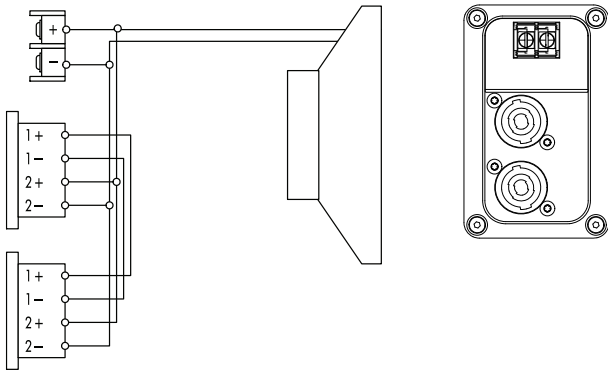

**Fig. 2: Connector wiring**

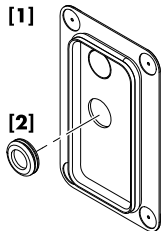

**Fig. 3: Cover plate and rubber grommet**

## 2.2. Connections

The cabinets are fitted with a pair of NL4 connectors and a two pole screw terminal block (ST). All four pins of both NL4 connectors are wired in parallel. The cabinets use the pin assignments 2+/2-. Pins 1+/1- are designated to full range cabinets.

Cabinets with the weather resistant option (WR) are equipped with a fixed input cable (PG type, H07-RN-F, 2 x 2.5 mm<sup>2</sup> (AWG 13), standard length 5.5 m (18 ft).

Pin equivalents of the applicable connector options are listed in the table below.

NL4	1+	1-	2+	2-
ST	n.a.	n.a.	+	-
PG	n.a.	n.a.	Brown (+)	Blue (-)

### Fixed cable connection

The 18S-SUB and 18A-SUB loudspeakers are each supplied with a cover plate [1] and a rubber grommet feed through [2]. For indoor operation, these items can be used to hide the connector panel, if required. For unprotected outdoor operation, the connector panel must be covered, i.e. both items must be used to achieve an IP degree of protection of IP34.

To install the fixed cable connection, proceed as follows:

**Tools required:** Philips screw driver (#PH2).

1. Prepare the rubber grommet and the connection cable.
2. Remove the knockout opening in the cover plate and attach the rubber grommet correspondingly.
3. Insert the connection cable through the rubber grommet and connect the cable wires to the screw terminal.  
⇒ Observe the correct polarity!
4. Undo the four screws of the connector panel.
5. Push the cover plate towards the connector panel until it fits into place.
6. Finally fix the cover plate together with the connector panel using the four screws.

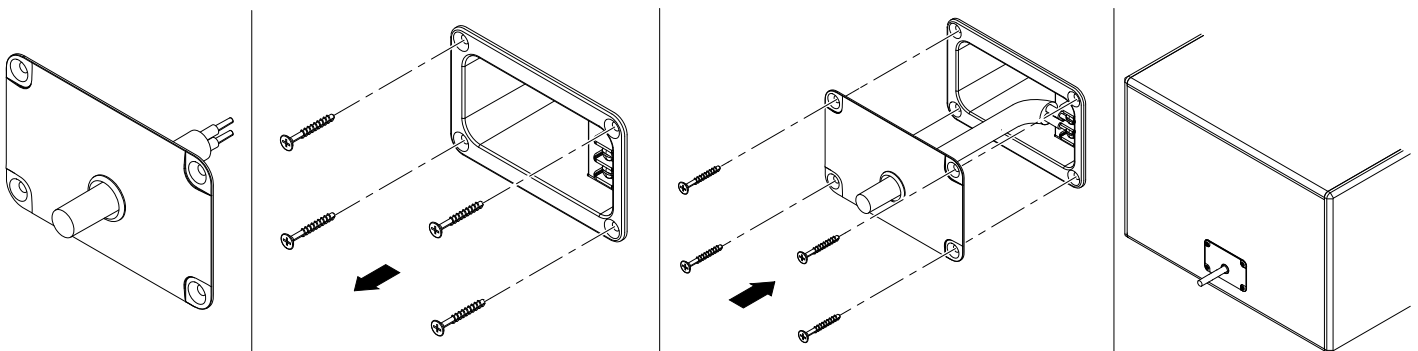

**Fig. 4: Installing the fixed cable connection**

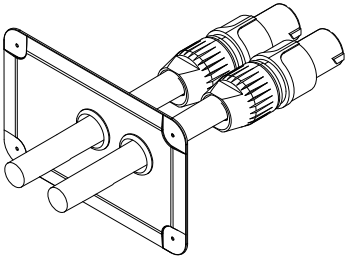

**Fig. 5: NL4 cable connection with cover plate [1]**

### NL4 connection with cover plate

The two NL4 connector sockets of the cabinet's connector panel are located in a recess to allow the use of the cover plate [1] together with NL4 cable connectors, as shown in the graphic opposite.

**Note:** Neutrik NL4FC type connectors must be used for this option.

The cover plate is equipped with two knockout openings to allow daisy chaining of the loudspeaker.

To use the NL4 connection, proceed in the same manner as described above in the section entitled ⇒ "Fixed cable connection" on page 6.

## 2.3. Operation

---

### NOTICE!

---

Only operate d&b loudspeakers with a correctly configured d&b amplifier, otherwise there is a risk of damaging the loudspeaker components.

#### Applicable d&b amplifiers:

10D/30D/D6/D12/D20/D80.

---

Application	Setup	Cabinets per channel
<b>18S-SUB/ 18A-SUB</b>	18S-SUB	2

Within applicable d&b amplifiers, the controller setup is available in Dual Channel or Mix TOP/SUB mode.

### 2.3.1. Controller settings

For acoustic adjustment the 100 Hz function can be selected.

#### 100 Hz circuit

If the 100 Hz circuit is selected, the upper operating frequency of the system is reduced from 140 Hz to 100 Hz.

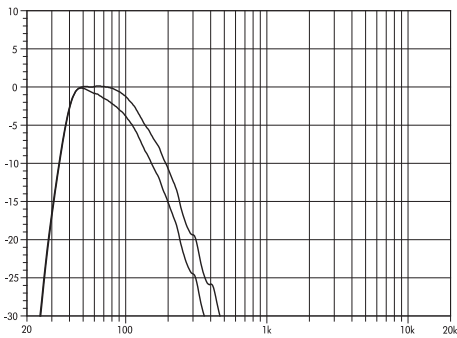

**Fig. 6: 185-SUB frequency response, standard and 100 Hz modes**

## 2.4. Technical specifications

### 185-SUB/18A-SUB system data

Frequency response (-5 dB standard) .....	37 Hz - 140 Hz
Frequency response (-5 dB 100 Hz mode) .....	37 Hz - 100 Hz
Max. sound pressure (single cabinet, 1 m, free field) .....	
with 10D/D6 .....	129 dB
with 30D/D20/D12 .....	132 dB
with D80 .....	132 dB
..... (SPLmax peak, pink noise test signal with crest factor of 4)	

### 185-SUB/18A-SUB loudspeaker

Nominal impedance .....	8 ohms
Power handling capacity (RMS/peak 10 ms) .....	400/1600 W
Components .....	1 x 18" driver
Connections .....	2 x NL4
.....	1 x screw terminal (ST - up to 4 mm <sup>2</sup> /AWG 11)
Optional fixed cable (PG): .....	
.....	H07-RN-F, 2 x 2.5 mm <sup>2</sup> (AWG 13), 5.5 m (18 ft)
Pin assignment .....	NL4: 2+/2-
.....	Fixed cable (PG): brown + / blue -
Weight .....	32 kg (71 lb)

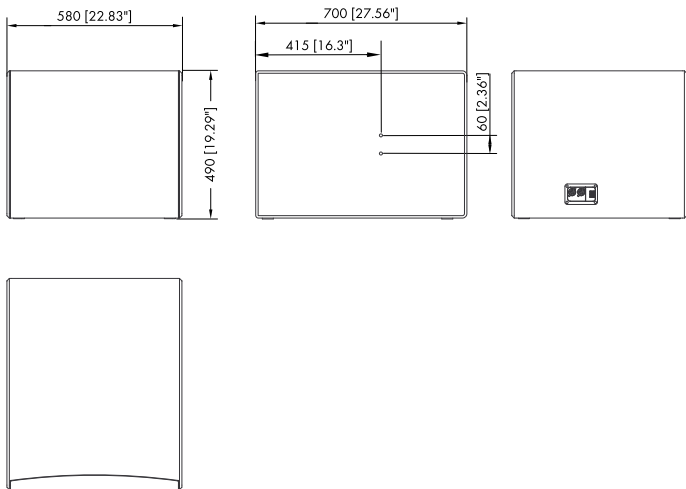

**Fig. 7: 185-SUB cabinet dimensions in mm [inch]**

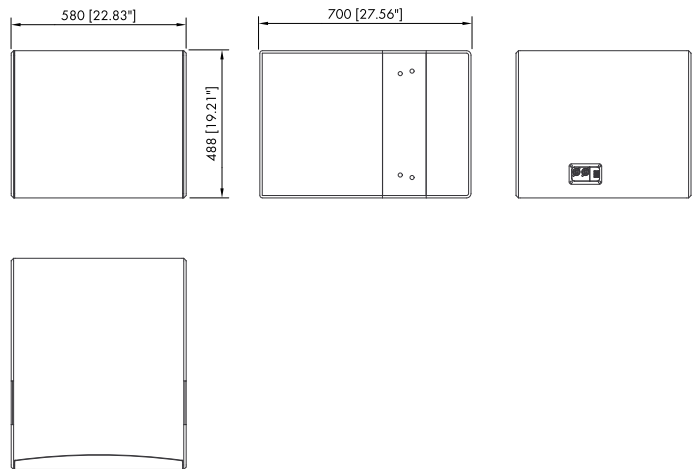

**Fig. 8: 18A-SUB cabinet dimensions in mm [inch]**





### 3.1. EU conformity of loudspeakers (CE symbol)

This declaration applies to:

**d&b 18S-SUB loudspeaker, Z1570/Z1626**

**d&b 18A-SUB loudspeaker, Z1571/Z1627**

manufactured by d&b audiotechnik GmbH.

All production versions of these types are included, provided they correspond to the original technical version and have not been subject to any later design or electromechanical modifications.

We herewith declare that said products are in conformity with the provisions of the respective EC directives including all applicable amendments.

A detailed declaration is available on request and can be ordered from d&b or downloaded from the d&b website at [www.dbaudio.com](http://www.dbaudio.com).

### 3.2. WEEE Declaration (Disposal)

Electrical and electronic equipment must be disposed of separately from normal waste at the end of its operational lifetime.

Please dispose of this product according to the respective national regulations or contractual agreements. If there are any further questions concerning the disposal of this product, please contact d&b audiotechnik.



