

**Electro-Voice®**

a gulton company

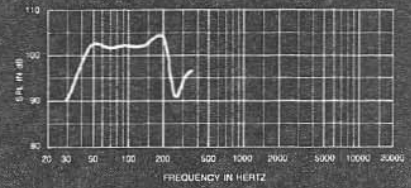

**FIGURE 1**  
Axial Frequency Response  
1 Watt/1 Meter

# Model MTL-4 Manifold Technology™ Low-Frequency Sound Reinforcement System

## SPECIFICATIONS

Frequency Response, 10 Feet on Axis,  
Swept One-Third-Octave Pink Noise,  
Anechoic Environment (see Figure 1):  
40-225 Hz

Low-Frequency 3-dB-Down Point:  
40 Hz

Usable Low-Frequency Limit  
(10-dB-down point):  
32 Hz

Half-Space Reference Efficiency:  
12.5%

Long-Term Average Power Handling  
Capacity per EIA Standard RS-426A  
(see Power Handling Capacity section):  
1600 watts

Short-Term Power Handling Capacity  
(10 milliseconds):  
6400 watts

Maximum Long-Term Average  
Midband Acoustic Output:  
200 watts

Sound Pressure Level at 1 Meter,  
Indicated Input Power, Anechoic Environ-  
ment, Band-Limited Pink-Noise Signal,  
50-200 Hz,

1 Watt: 102 dB  
1600 Watts: 134 dB  
6400 Watts: 140 dB

Dispersion Angle Included by  
6-dB-Down Points on Polar Responses,  
Indicated One-Third-Octave Bands of  
Pink Noise, 80-160 Hz Horizontal and  
Vertical (see Figure 3):  
177° ± 37°

Directivity Factor  $R_{\theta}$  (Q), Median  
over 80-160-Hz Range  
(see Figure 4):  
2.84

Directivity Index  $D_i$ , Median  
over 80-160-Hz Range  
(see Figure 4):  
4.5 dB

Distortion, 0.1 Full Power Input  
(see Figure 5),

Second Harmonic,  
50 Hz: 0.6%  
100 Hz: 0.5%

Third Harmonic,  
50 Hz: 0.6%  
100 Hz: 0.2%

Distortion, Full Power Input  
(see Figure 6),

Second Harmonic,  
50 Hz: 1.4%  
100 Hz: 1.8%

Third Harmonic,  
50 Hz: 2.0%  
100 Hz: 0.8%

Transducer Complement:  
Four DL18W

Box Tuning Frequency:  
37 Hz

Impedance,  
Nominal:  
Two 4-ohm loads  
Minimum:  
Two 4-ohm loads

Input Connections:  
Canon EP-4-14

Enclosure Materials:  
14-ply Baltic birch plywood

Hanging:  
Two-point flying system optional

Dimensions,  
Height:  
91.4 cm (36.0 in.)  
Width:  
91.4 cm (36.0 in.)  
Depth:  
76.2 cm (30.0 in.)

Net Weight:  
119 kg (263 lb)

Shipping Weight:  
134 kg (297 lb)

## DESCRIPTION

The Electro-Voice MTL-4 "Manifold Technology" low-frequency loudspeaker system was designed for high-level concert sound reinforcement in touring sound and permanent installation applications. The MTL-4 is a vented-box design comprised of four DL18W woofers, each facing into a manifold chamber at the center of the cabinet. This manifolding technique<sup>1</sup> results in increased acoustic loading, yielding increased low-frequency efficiency and reduced distortion over conventional direct-radiating designs in a remarkably small enclosure. The MTL-4 is typically 2-3 dB

1. Patent pending.

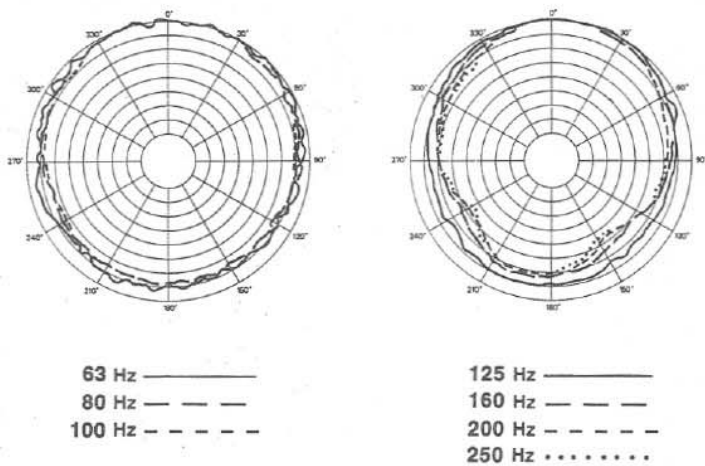

**FIGURE 2 — MTL-4 Polar Response**  
 (1/3 octave, 4 volts/10 feet)

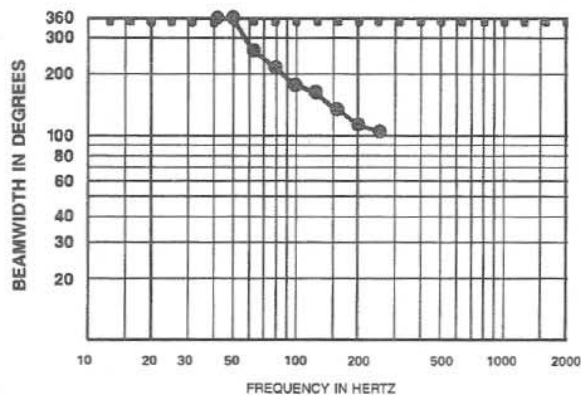

**FIGURE 3**  
 MTL-4 Beamwidth vs. Frequency

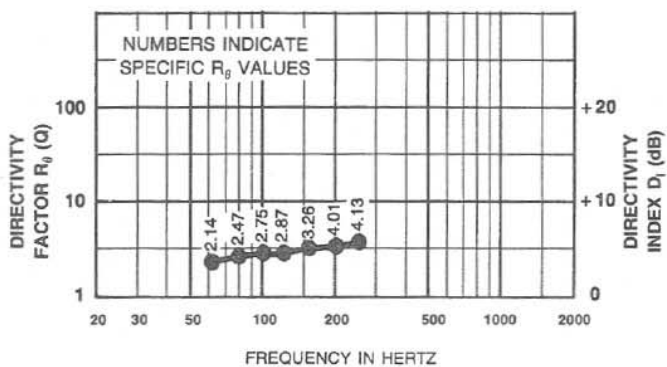

**FIGURE 4 — MTL-4 Directivity Factor and Directivity Index vs. Frequency**

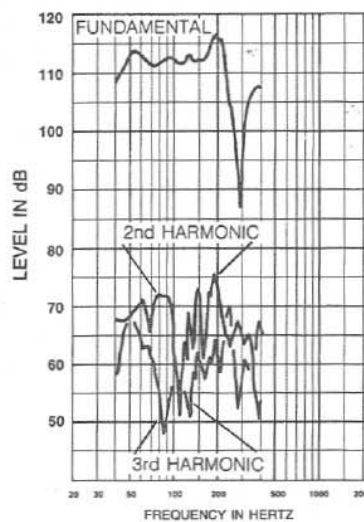

**FIGURE 5 — MTL-4 Harmonic Distortion, 0.1 Rated Power Input**  
 (160 watts, 10 Feet on Axis)

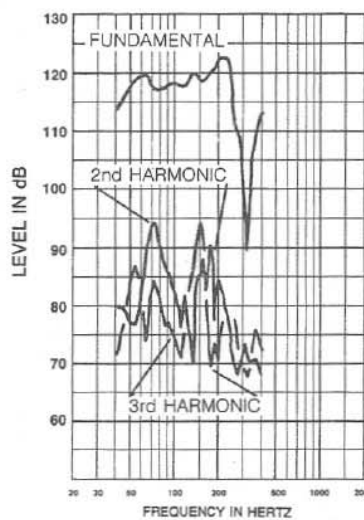

**FIGURE 6 — MTL-4 Harmonic Distortion, 1.0 Rated Power Input**  
 (1600 watts, 10 Feet on Axis)

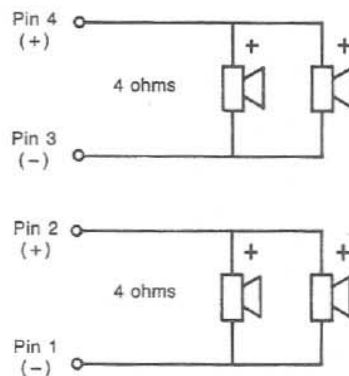

**FIGURE 7**  
 MTL-4 Wiring Diagram

more efficient than horn-loaded enclosures of equivalent size in the 40-80-Hz region. Additionally, this radical design allows for efficient heat-transfer from the loudspeakers to minimize thermal build-up during extended periods of high-power operation.

Designed to survive the rigors of the road, the MTL-4 is constructed of 14-ply Baltic birch plywood and is covered with black Ozite Super TNT carpeting (the most rugged in the industry). For permanent installations the MTL-4 is available with a black textured paint finish. Both versions feature a black nylon cloth grille and have flying hardware and removable dolly options.

#### APPLICATIONS

The MTL-4 is ideal for any professional touring or installation application requiring low-frequency reproduction at high sound pressure levels with low distortion. Manifold technology maximizes the acoustic output per bulk volume and frontal area of the enclosure, enabling more compact systems and arrays than would be obtainable with conventional sound reinforcement enclosure designs. Additionally the MTL-4 is more directional than most low-frequency loudspeaker systems.

The dimensions of the MTL-4 were chosen for efficient truck pack and high-density array design. The cabinets may be stacked three high and three wide in a standard tractor trailer allowing for over 14,000 watts of bass system to be accommodated in only three feet of truck floor length. Careful attention was paid to details to provide both the touring company and the sound contractor with a convenient and time-saving professional sound reinforcement package.

#### FREQUENCY RESPONSE

The MTL-4 frequency response was measured in an anechoic environment at one meter on axis with a one-watt swept one-third-octave pink noise input. (See Figure 1)

#### DIRECTIVITY

The MTL-4 directional characteristics were measured by running a set of polar-response curves in EV's large anechoic chamber. The test signal was one-third-octave pseudo-random pink noise centered at the frequencies indicated in Figure 2. Because the MTL-4 is essentially symmetrical, only a single polar-response curve is shown.

Additional typical information is provided in Figure 3 which shows 6-dB-down beamwidth versus frequency. Figure 4 shows the directivity factor and directivity index versus frequency.

#### DISTORTION

Following AES (Audio Engineering Society) recommended practice, plots of second- and third-order harmonic distortion for 0.1 rated input power are shown in Figure 5. Figure 6 shows distortion at full rated input power.

#### POWER HANDLING CAPACITY

To our knowledge, Electro-Voice was the first U.S. manufacturer to develop and publish a power test closely related to real-life conditions. First, we use a random noise input signal because it contains many frequencies simultaneously, just like real voice or instrument program. Second, our signal contains more energy at extremely high and low frequencies than typical actual program, adding an extra measure of reliability. Third, the test signal includes not only the overall "long-term average" or "continuous" level — which our ears interpret as loudness — but also short-duration peaks which are many times higher than the average, just like actual program. The long-term average level stresses the speaker thermally (heat). The instantaneous peaks test mechanical reliability (cone and diaphragm excursion). Note that the sine-wave test signals sometimes used have a much less demanding peak value relative to their average level. In actual use, long-term average levels exist from several seconds on up, but we apply the long-term average for several hours, adding another extra measure of reliability.

Specifically, the MTL-4 is designed to withstand the power test described in EIA Standard RS-426A. The EIA test spectrum is applied for eight hours. To obtain the spectrum, the output of a white noise generator (white noise is a particular type of random noise with equal energy per bandwidth in Hz) is fed to a shaping filter with 6-dB-per-octave slopes below 40 Hz and above 318 Hz. When measured with the usual constant-percentage analyzer (one-third-octave), this shaping filter produces a spectrum whose 3-dB-down points are at 100 Hz and 1,200 Hz with a 3-dB-per-octave slope above 1,200 Hz. This shaped signal is sent to the power amplifiers with continuous power set at 800 watts into each of the 3.45 ohms EIA equivalent impedance inputs

(52.5 volts true RMS), resulting in a total of 1600 watts of continuous power being delivered to the MTL-4.

Amplifier clipping sets instantaneous peaks at 6 dB above the continuous power, or 6400 watts peak (105 volts peak per input). This procedure provides a rigorous test of both thermal and mechanical failure modes.

#### SUBPASSBAND SPEAKER PROTECTION

Below the enclosure tuning frequency, cone excursion increases rapidly. Since acoustic output is also falling rapidly, there is no utility in driving the system with signals much below the tuning frequency. While such signals may be in the program material, they are often extraneous — such as from record-surface irregularities (strong 5-25-Hz components) or a drooped microphone. The DL18W very-low-frequency reproducer is ruggedly designed and has a high maximum excursion before damage ( $\pm 0.5$  inch.). However, high-output subwoofer systems such as the MTL-4 should be protected by a high-pass filter with a 3-dB-down corner frequency of about 0.8 the enclosure tuning frequency (approximately 30 Hz). Below the corner frequency, a rolloff of at least 12-dB-per-octave should be used.

Without protection, subpassband signals may "bottom" the DL18W. Damage will probably result, especially after repeated occurrences. Even if bottoming does not occur, the subpassband signals waste amplifier power and modulate (distort) the frequencies which are within the MTL-4's operating range. Much "woofer distortion" or "muddy bass" can be attributed to lack of subpassband protection.

#### LARGE-SIGNAL PERFORMANCE

Speakers have two limitations that govern their large-signal, or maximum-output, performance capabilities. One is the speaker's long-term average power capacity (related to thermal, or heat, destruction). The second is its maximum linear cone-excursion ability (as expressed in the Thiele-Small parameter,  $X_{max}$ ). One of the benefits of the MTL-4 manifold technology design is that with full power input (1600 w) the maximum recommended cone excursion of the DL18W woofer is not exceeded for any frequency above the box-tuning frequency of 37 Hz. Therefore, the only limitation of the MTL-4 low-frequency system in the recommended frequency range is the thermal input power. Cone excursion increases substantially below box-tuning and operation is not recommended for frequencies below 37 Hz (see Subpassband Speaker Protection section).

#### USE IN MULTIPLES

MTL-4's may be used in multiples to increase acoustic output. In the following discussion, it is assumed that all speaker cones are operating in unison (in phase) when a common signal is applied. A 6-dB increase in maximum acoustic output results when two speaker systems are located side by side. For operation at very low frequencies, the woofer cones "mutually couple," acting as one system with cone area and power-handling capacity twice that of a single system. The doubling of cone area doubles efficiency, providing a 3-dB increase in sound pressure level. The second 3-dB comes from the doubling of power capacity.

Mutual coupling occurs when the frequency is such that the center-to-center distance between the two woofer manifolds is less than about one-half wavelength. When the distance is greater than one-half wavelength, as would occur if two MTL-4's were widely spaced, the level increase tends to be limited to the 3-dB power-handling increase.

#### SYSTEM POSITIONING

Subwoofer systems such as the MTL-4 are often located on the floor. This is both convenient and can provide a desired high acoustic impact when the speakers are, for example, placed near the periphery of a dance floor. In other installations, such as a theatre or auditorium, the audible location of a subwoofer operating at sufficiently low crossover frequency (below about 125 Hz) will not be particularly evident. The other system elements operating above the subwoofer range can be positioned for the desired locational cues and uniform audience coverage.

Floor location provides the acoustic half-space environment associated with the 12.5% system efficiency noted in the Specifications section. Location at a floor-wall junction (acoustic quarter space) doubles efficiency (a 3 dB increase in sound pressure level) and tends to promote the full excitation of more room modes, or standing waves, important in achieving maximum overall bass output in the room. Corner placement (acoustic eighth space) doubles efficiency again and guarantees excitation of all room modes. (Such placement for maximum efficiency and room-mode excitation is not necessary and may not be desirable or possible for a variety of reasons, including esthetics and practicality.)

The MTL-4 can also be successfully operated away from any nearby acoustic boundaries, particularly when multiple systems are used for increased output ability (see Use in Multiples section), such as in a flown concert system.

#### CONNECTION

The MTL-4 has four 8-ohm loudspeakers wired in paralleled pairs resulting in two 4-ohm loads accessed by a 4-pin connector at the back of the enclosure. The connector used is the Cannon EP-4-14 (male), and the pin-out arrangement and wiring diagram is shown in Figure 7. The mating connector for the cable end is the Cannon EP-4-11-1C.

#### HANGING

The MTL-4 may be ordered with an optional two-point flying hardware system. In addition to a time savings in setup, this unique two-point system permits a wide range of angle adjustments and offers maximum flexibility in array design and implementation for both the sound touring company and the sound contractor.

#### WARRANTY (Limited)

Electro-Voice Speakers and Speaker Systems (excluding active electronics) are guaranteed for five years from date of original purchase against malfunction due to defects in workmanship and materials. If such malfunction occurs, unit will be repaired or replaced (at our option) without charge for materials or labor if delivered prepaid to the proper Electro-Voice service facility. Unit will be returned prepaid. Warranty does not extend to finish, appearance items, burned coils, or malfunction due to abuse or operation under other than specified conditions, including cone and/or coil damage resulting from improperly designed enclosures, nor does it extend to incidental or consequential damages. Some states do not allow the exclusion or limitation of incidental or consequential damages, so the above exclusion may not apply to you. Repair by other than Electro-Voice or its authorized service agencies will void this guarantee. A list of authorized warranty service agencies is available from Electro-Voice, Inc., 600 Cecil Street, Buchanan, MI 49107 (AC/616-695-6831); Electro-Voice, Inc., 3810 148th Avenue N.E., Redmond, WA 98052 (AC/206-881-9555); and/or Electro-Voice West, 8234 Doe Avenue, Visalia, CA 93291 (AC/209-651-7777). This warranty gives you specific legal rights, and you may also have other rights which vary from state to state.

Service and repair address for this product: Electro-Voice, Inc., 600 Cecil Street, Buchanan, Michigan 49107.

Specifications subject to change without notice.



**ELECTRO-VOICE, INC., 600 Cecil Street, Buchanan, Michigan 49107**

MANUFACTURING PLANTS AT ■ BUCHANAN, MI ■ NEWPORT, TN ■ SEVIERVILLE, TN ■ REDMOND, WA ■ GANANOQUE, ONT.  
©Electro-Voice, Inc. 1986 ■ Litho In U.S.A.

a gulton company

Part Number 530676-622-

**Fax Transmission**

To: Joe Martin

Fax No.: 317-770-1823

Number of Pages: 1

From: DE Carlson

Date: October 15, 1999

Subject: MTL-4 Rewiring

cc:



a division of Telex Communications  
**Acoustic Engineering R&D Center**  
128 East Front Street  
Buchanan, MI 49107 USA  
Tel: 616-695-6831  
800-234-6831  
Fax: 616-695-9626  
e-mail: [de.carlson@telex.com](mailto:de.carlson@telex.com)  
[dcarlson@qtm.net](mailto:dcarlson@qtm.net)  
Altec-Lansing, DDA, Dynacord, Electro-Voice,  
Klarck Teknik, Merlin, Telex, Vega

ORIGINAL WIRING:

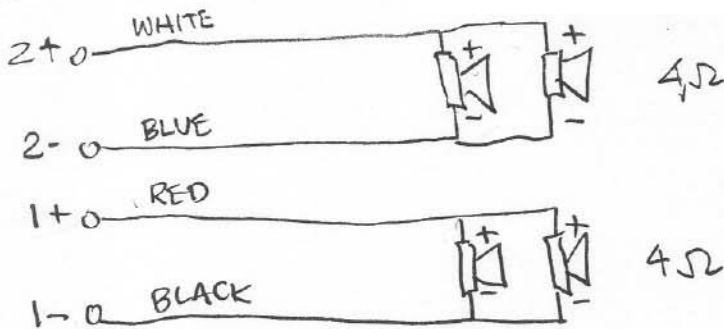

NEW WIRING

