

# 2000 Series

## General Description

The 2000 Series wireless microphone systems are targeted primarily at rental houses and mid-level theatre and broadcast applications. It includes a wide variety of products, from wireless microphones to personal monitoring equipment to portable ENG kits.

## Features

- Competitive price points and a comprehensive, professional feature set
- Compatible with all generations of evolution wireless for ultimate wireless flexibility that serves all price points and applications. Sennheiser is the only brand on the market that offers such in-depth product integration!
- The output power of all transmitters is switchable from 10 / 30 / 50 / 100 mW
- Directly connects to networks via an Ethernet port and can be controlled with Sennheiser's "Wireless Systems Manager" (WSM) software
- Available in three ranges in the U.S. with a switching bandwidth between 42-72 MHz
- Ranges include: A (516/558), G (558/626), B (626/698)
- Via an antenna loop-through, up to eight dual channel rack-mount receivers can be daisy-chained without the need for an external splitter
- External charging contacts on all transmitters makes "going green" easier, and saves money over time on battery consumption



### SK 2000

- Rugged housing with metal battery flap
- Extended frequency response (25 – 20,000 Hz) especially complements bass guitars
- 3-pin special socket for use with professional accessories
- Switchable output power of 10 / 30 / 50 / 100 mW
- External charging contacts



### EK 2000

- Single-channel camera receiver
- Display of transmitter battery and configuration status
- Adaptive Diversity
- IR synchronization of all TX



### EK 2000 IEM

- Stereo bodypack receiver
- Adaptive Diversity
- Rugged housing with metal battery flap
- Includes IE4



### EM 2000 / EM 2050

- Rack-mount single or dual channel receiver
- Professional design with:
  - full 19" metal housing
  - integrated power supply
  - integrated active splitter
- One Ethernet port per receiver
- 2 XLR outs + 2 jacks
- IR synchronization of all TX
- Display of transmitter battery and configuration status
- Equalizer and guitar tuner
- True Diversity



### SR 2000 / SR 2050

- Rack-mount single or dual channel transmitter
- Professional design with:
  - full 19" metal housing
  - integrated power supply
- One Ethernet port per transmitter
- 5-band graphic equalizer
- Switchable output power of 10 / 30 / 50 / 100 mW



### SKM 2000

- Switchable output power of 10 / 30 / 50 / 100 mW
- Available in black and nickel
- External charging contacts
- Ideal for rough stage use
- Compatible with all ew capsules:
  - 800 series (black)
  - 900 series (blue, black)
  - 965 (nickel, blue, black)

(Capsule sold separately)



### SKP 2000

- Plug-on transmitter makes any wired mic wireless
- Switchable output power of 10 / 30 / 50 / 100 mW
- Phantom powering

# Multi-Channel Wireless System Design

## Sixteen Channel 2000 Series Wireless System w/ Computer Control & Remote Monitoring

(8 Handheld Systems and 8 Lavalier Systems)

Qty	Model	Description
8	EM2050	Dual receiver
8	SKM2000	Handheld transmitter w/MMD935-1 capsules
8	SK2000	Bodypack transmitter
8	MKE2	Premium lavalier microphone
14	BB1	12" BNC cable
2	A5000CP	Circular-polarized directional antenna
1		24 Port switch (3rd Party)

Note: Various Lengths of RF cable available for antenna run (sold separately)

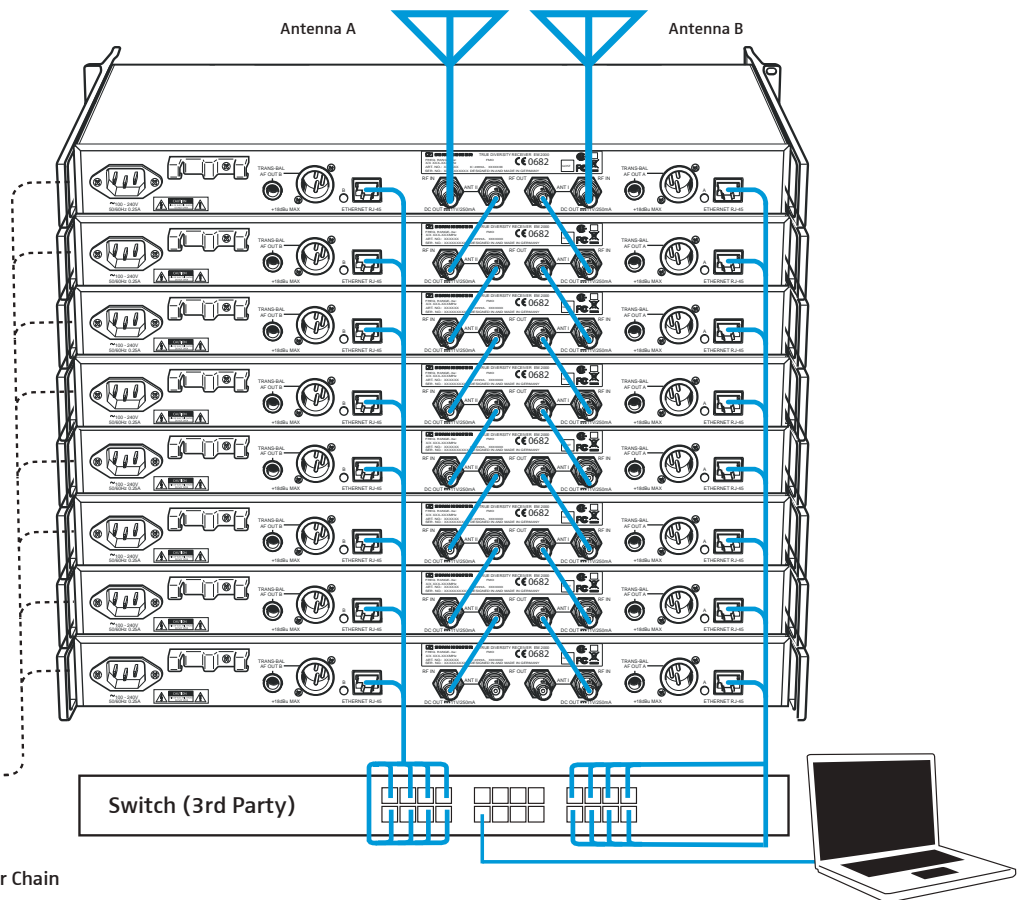
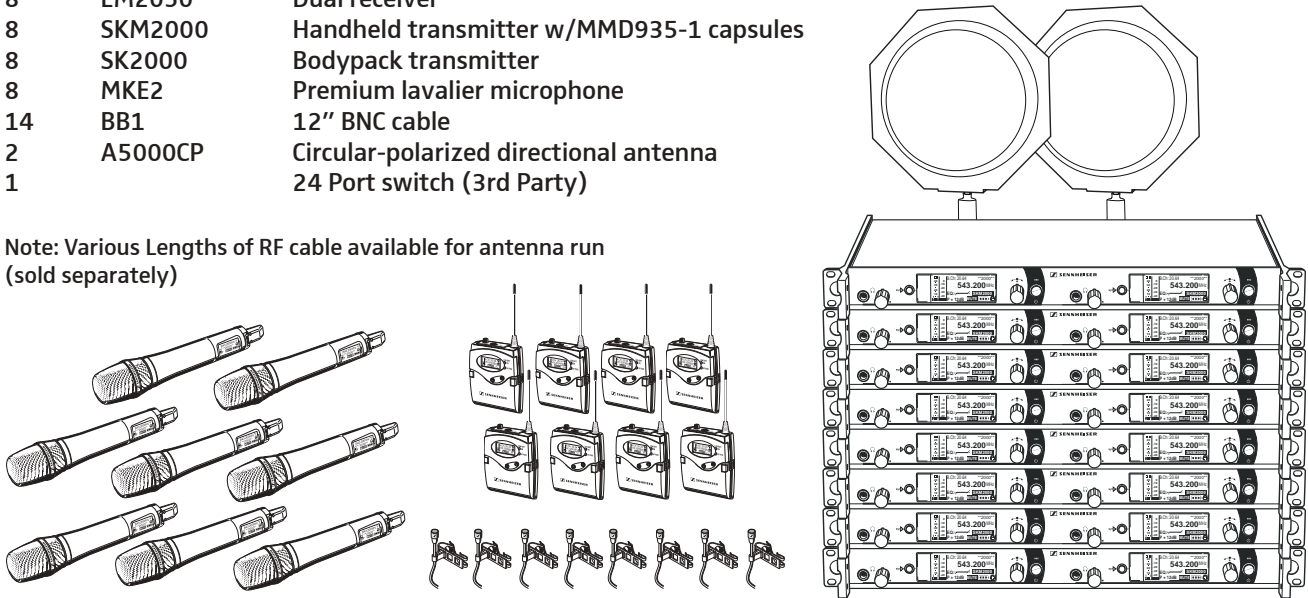

# 16 Channel Wireless System

# Multi-Channel Wireless System Design

## Sixteen Channel 2000 Series Wireless System w/ Computer Control & Remote Monitoring with K8 Digital Distribution

(8 Handheld Systems and 8 Lavalier Systems)

Qty	Model	Description
8	EM2050	Dual receiver
8	SKM2000	Handheld transmitter w/MMD935-1 capsules
8	SK2000	Bodypack transmitter
8	MKE2	Premium lavalier microphone
14	BB1	12" BNC cable
2	A5000CP	Circular-polarized directional antenna
2	K8-A18	8 Channel analog audio input for K8 digital distribution network
4	K8-A08	8 Channel analog audio line level output for K8 digital distribution network
1		24 Port switch (3rd Party)

Note: Various Lengths of RF cable available for antenna run (sold separately)

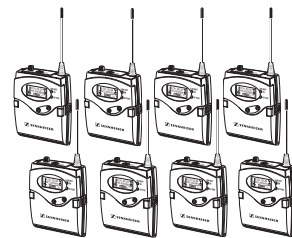
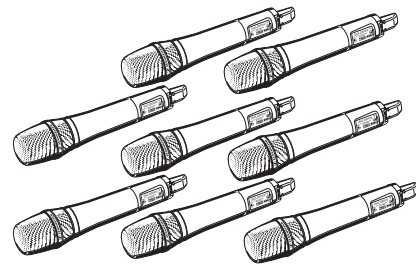
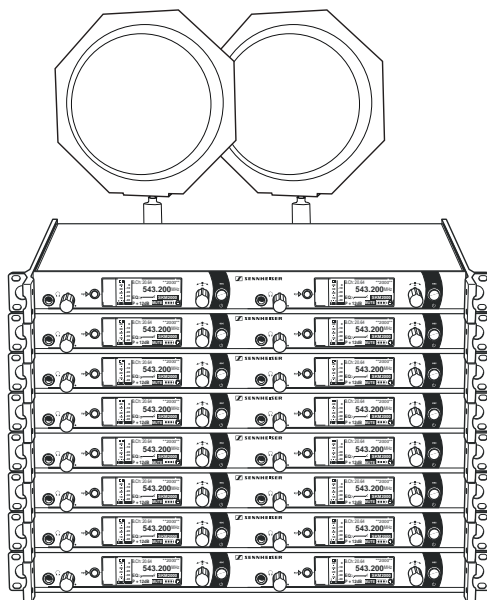

Switch (3rd Party)

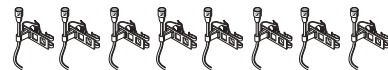

K8-A18

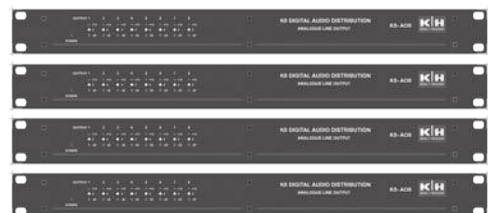

K8-A08

\*AB3 boosters may be used to compensate for RF loss associated with long cable runs.

# 16 Channel Wireless System

# Multi-Channel Wireless System Design

Sixteen Channel 2000 Series Wireless System w/ Computer Control & Remote Monitoring with K8 Digital Distribution  
 (8 Handheld Systems and 8 Lavalier Systems)

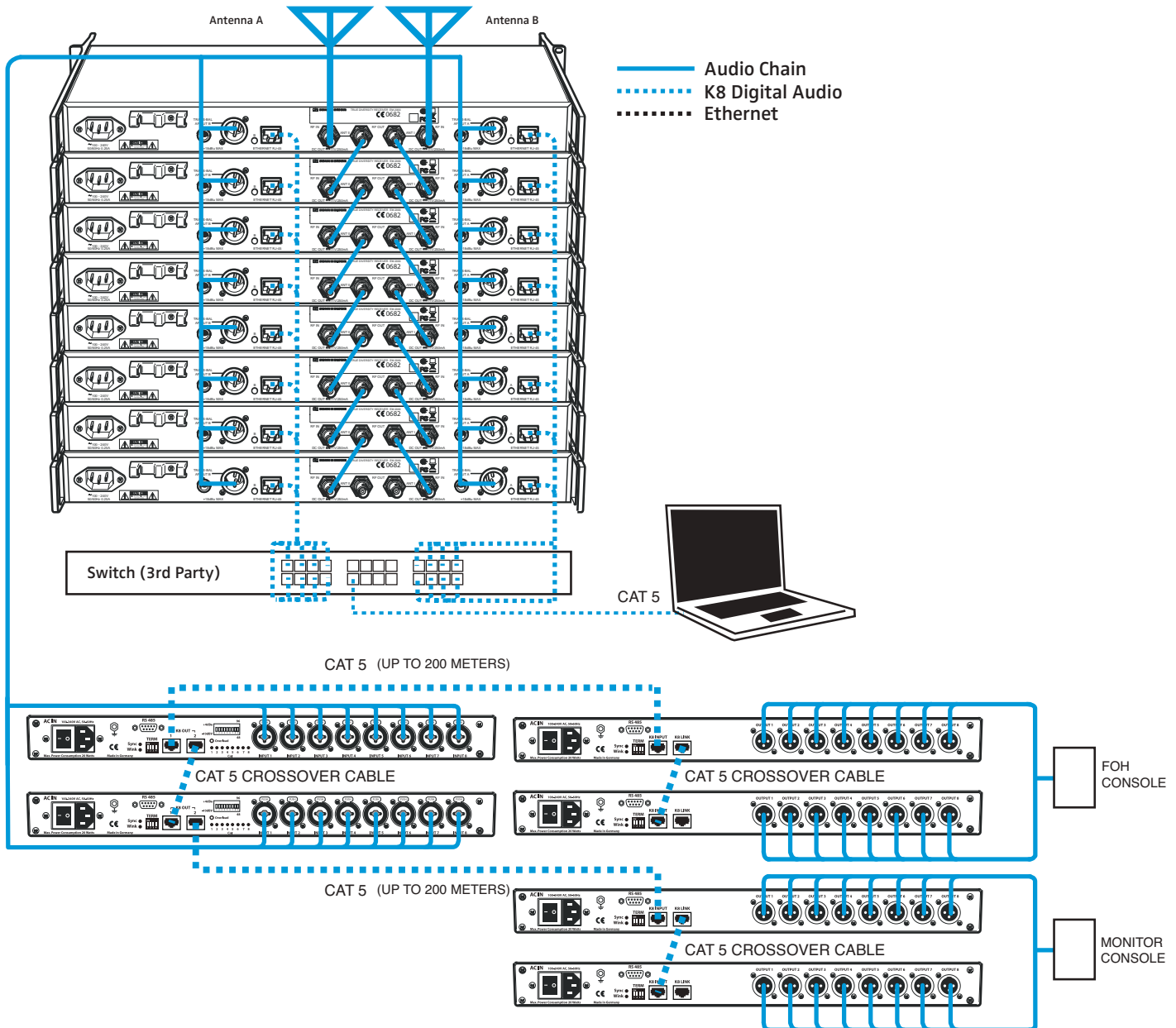

# ME102/104/105 Lavaliers

## ME102/104/105 Modular Lavalier System Components

Steel Mesh  
Windscreens

Microphone  
capsules

Connecting  
cables

Accessories

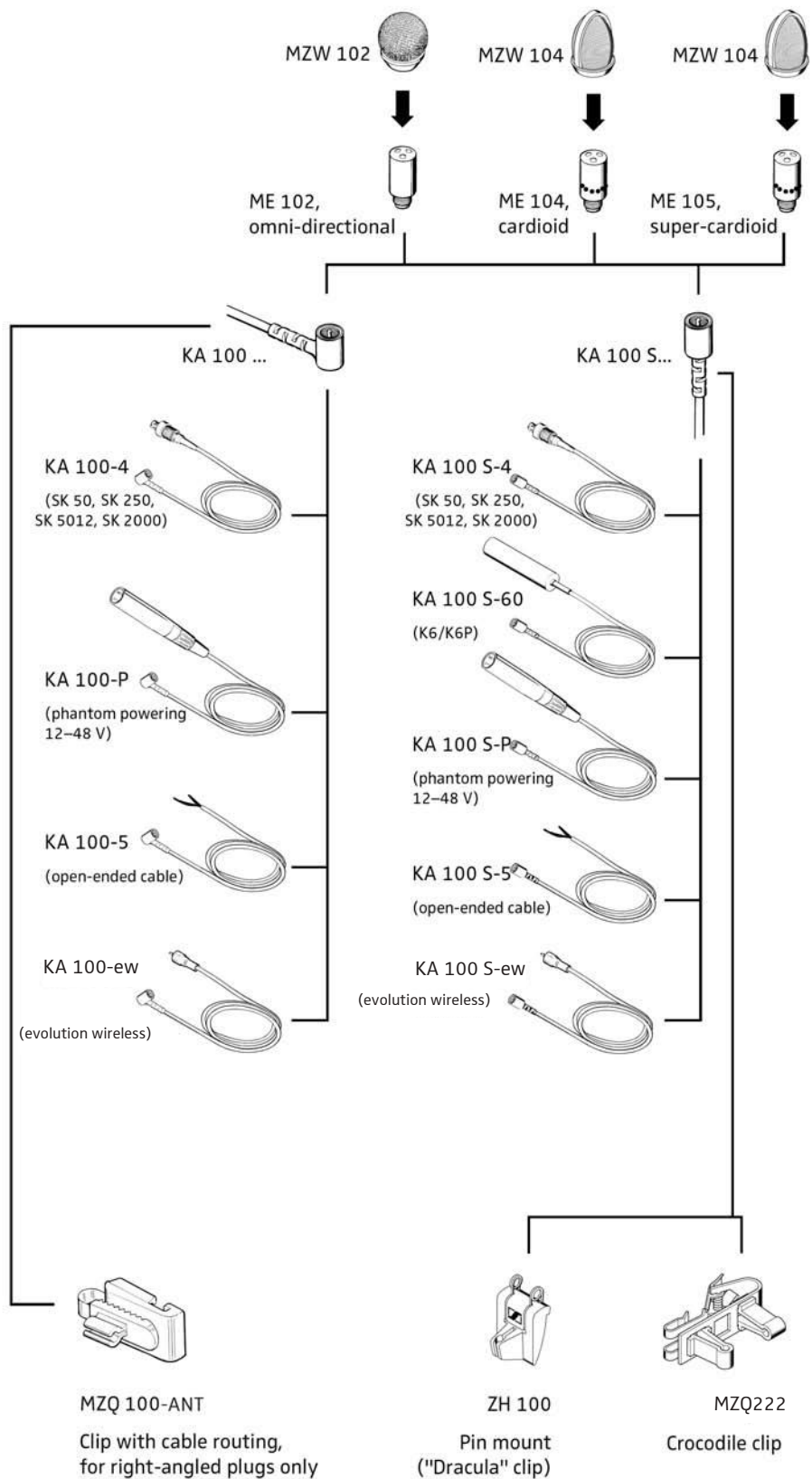

# ME102/104/105 Lavaliers