

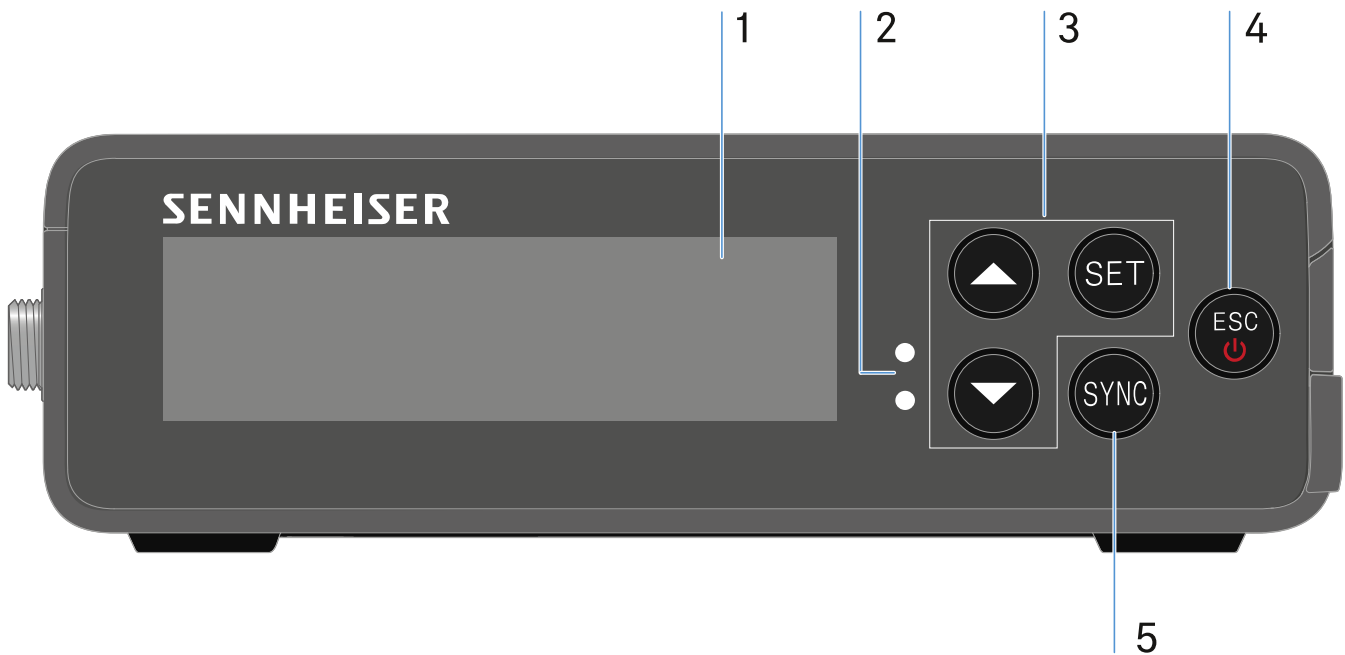

EW-DP EK portable receiver

Product overview

Front



- 1 Display for status information and operating menu
 - See "Displays on the receiver's display panel"
- 2 **LINK** and **DATA** LEDs to indicate connection status and Bluetooth status
 - See "Meaning of the LEDs"
- 3 **UP/DOWN/SET** menu buttons for navigating the operating menu
 - See "Making settings in the menu"
- 4 **ESC/ON/OFF** button for canceling an action in the menu or switching the device on and off
 - See "Making settings in the menu"
 - See "Switching the receiver on and off"
- 5 **SYNC** button for synchronizing the transmitter and receiver
 - See "Establishing a radio link | Synchronizing the receiver and transmitter"



Side

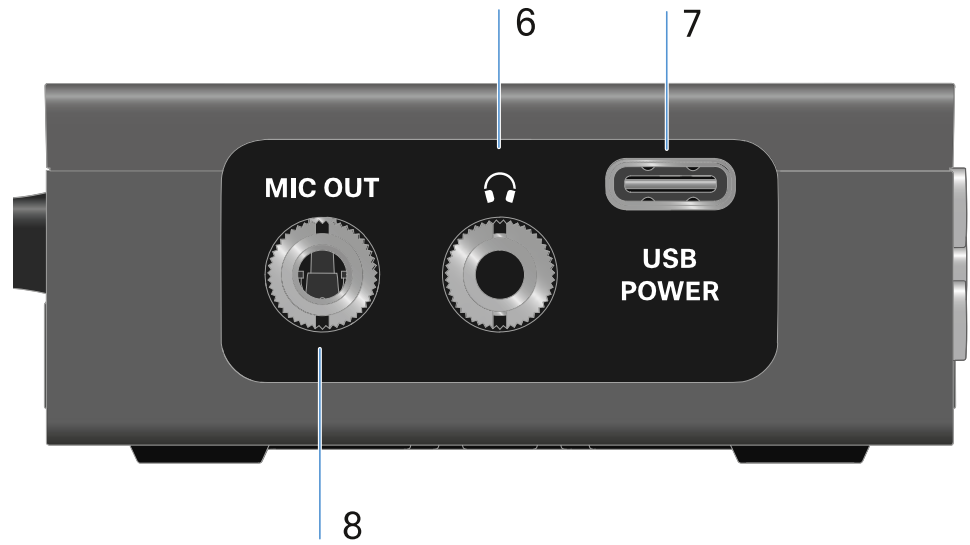

- 6 3.5 mm jack socket for headphones
 - See "Outputting audio signals"
- 7 USB-C connection socket for power supply
 - See "Power supply"
- 8 3.5 mm jack socket for connecting cable
 - See "Outputting audio signals"



Power supply

The EW-DP EK can be powered in two different ways:

Power supply via USB-C from a camera or power bank:

USB-C Power

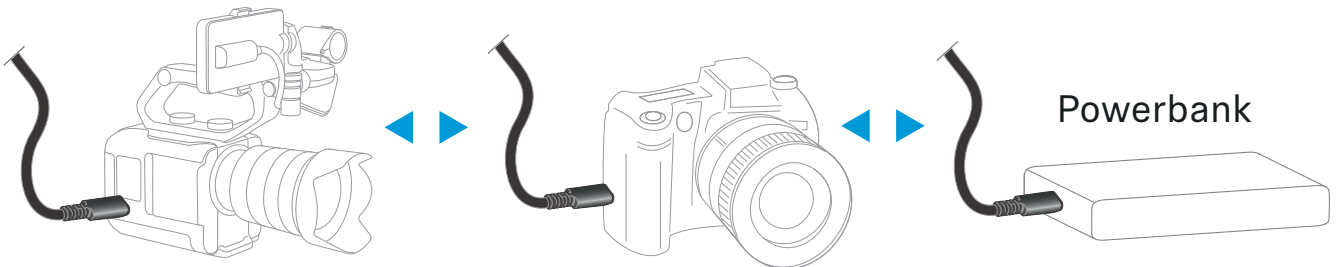

- ▷ Connect the receiver to a camera or other power supply using a USB-C cable.

Power supply via USB-C cable: 5 V/min. 1 A (for max. charging speed of the inserted BA 70)



Power supply via (rechargeable) batteries:

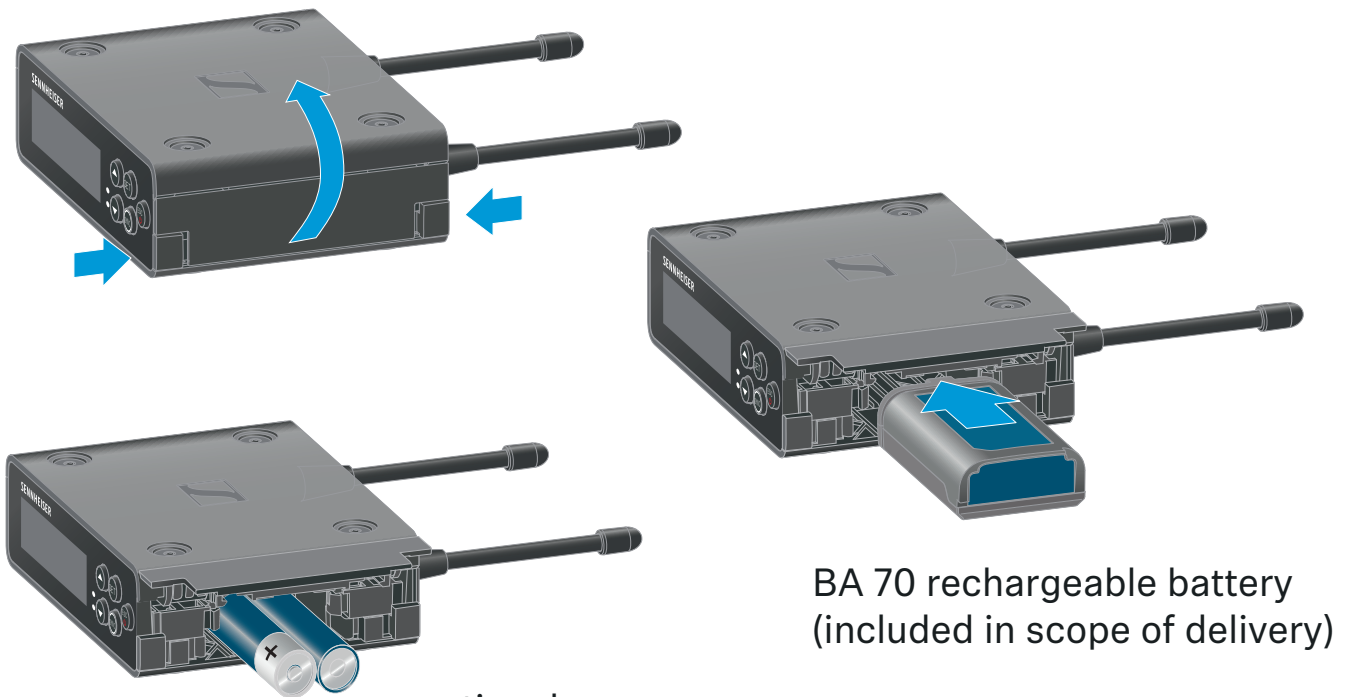

BA 70 rechargeable battery
(included in scope of delivery)

optional:
2 AA batteries

- ▷ Open the EW-DP EK unit's battery compartment by pressing in the two release buttons on the sides.
- ▷ Insert either a BA 70 rechargeable battery or 2 AA batteries.
- ▷ Close the battery compartment.

Primary batteries and USB can be used in parallel without restrictions, as this is controlled by the EK unit.

The EW-DP EK supports the USB Power Delivery Protocol for smart USB-C power supply units (USB-C PD).



Outputting audio signals

The EW-DP EK has an unbalanced 3.5 mm audio output and an unbalanced 3.5 mm headphone output.

CAUTION

Danger due to high volume levels

Volume levels that are too high may damage your hearing.

- ▷ Turn down the volume of the headphone output before you put on the headphone. Recommended impedance for headphones (HD 25 = 70 ohms). For headphones with < 32 ohms of impedance, the audio signal can be very loud at the lowest volume setting.
-

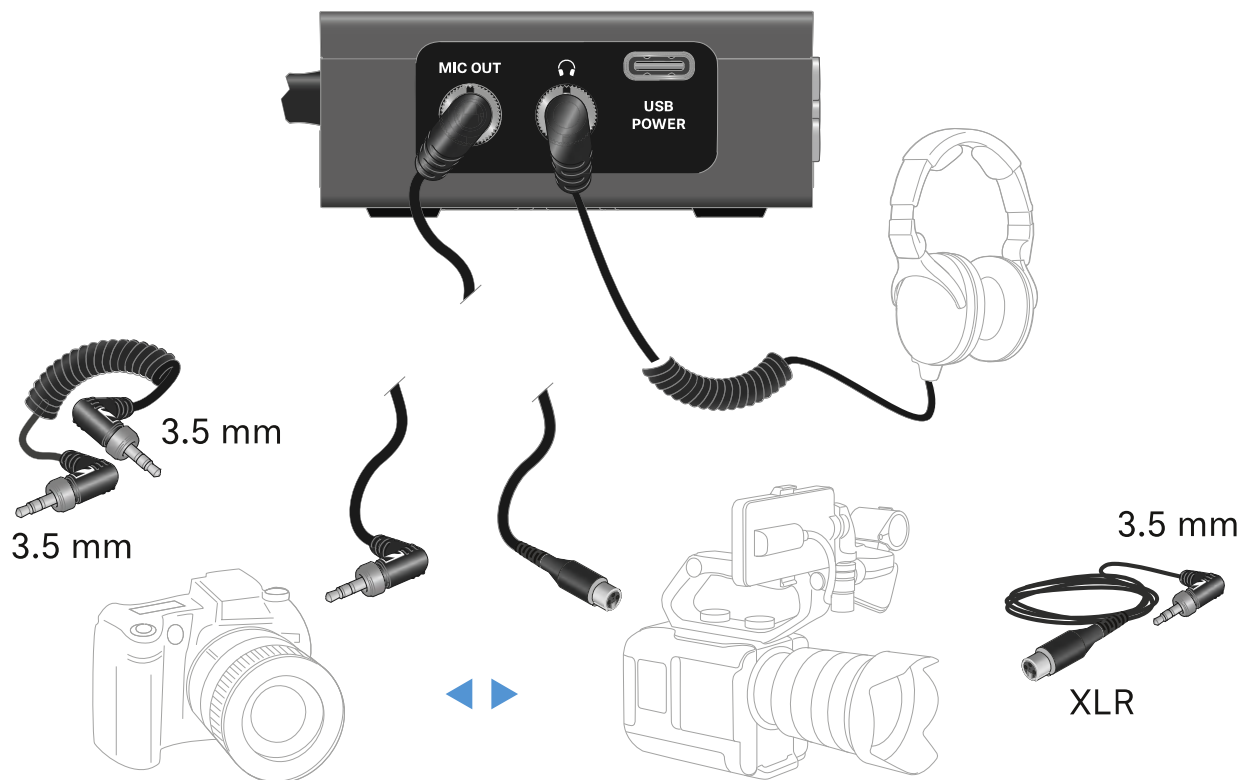

To connect a 3.5 mm jack cable:

- ▷ Plug the jack cable into the MIC OUT socket on the EW-DP EK.



Mounting the receiver / mounting options

EW-DP EK mounting accessories:





Combining the mounting plate and hot shoe adapter:

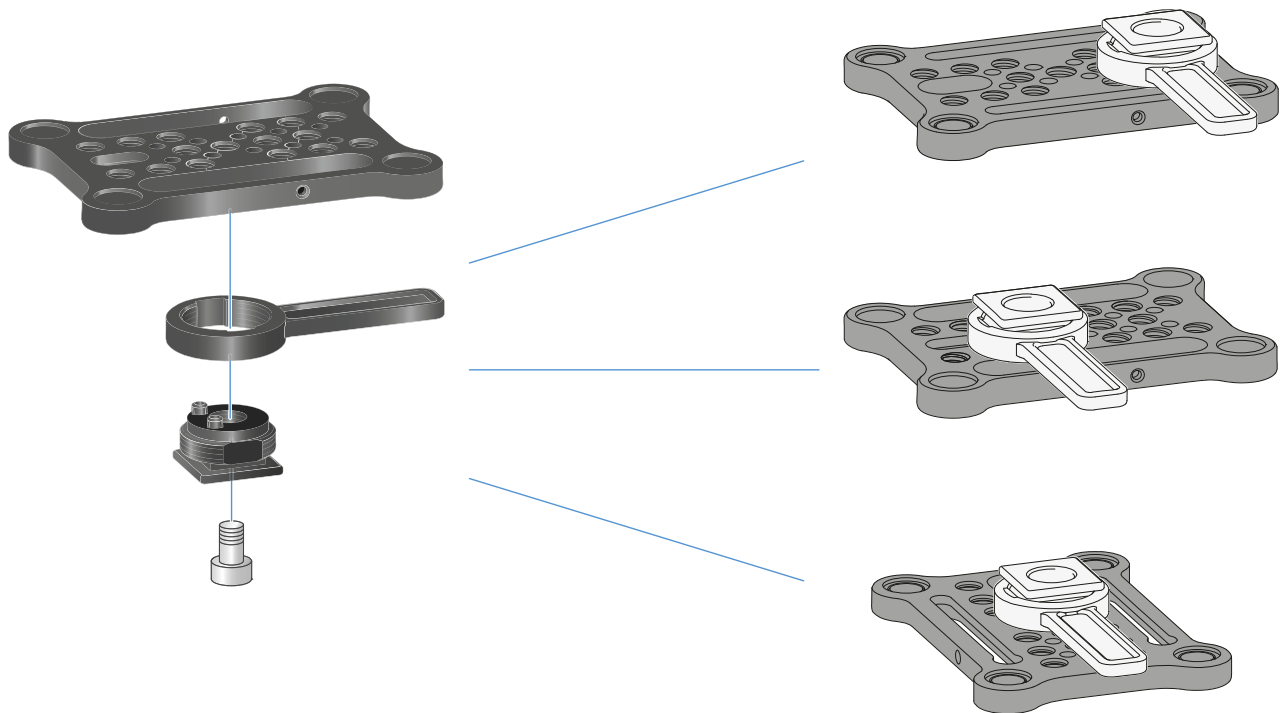

The **hot shoe adapter** can be fitted to the mounting plate in different positions according to the mounting situation.

To mount the hot shoe adapter on the mounting plate:

- ▷ Pre-assemble the hot shoe adapter by connecting the adapter and lever using the supplied screw.
- ▷ Then screw the hot shoe adapter to the mounting plate at the desired location.



Mounting plate and clip:

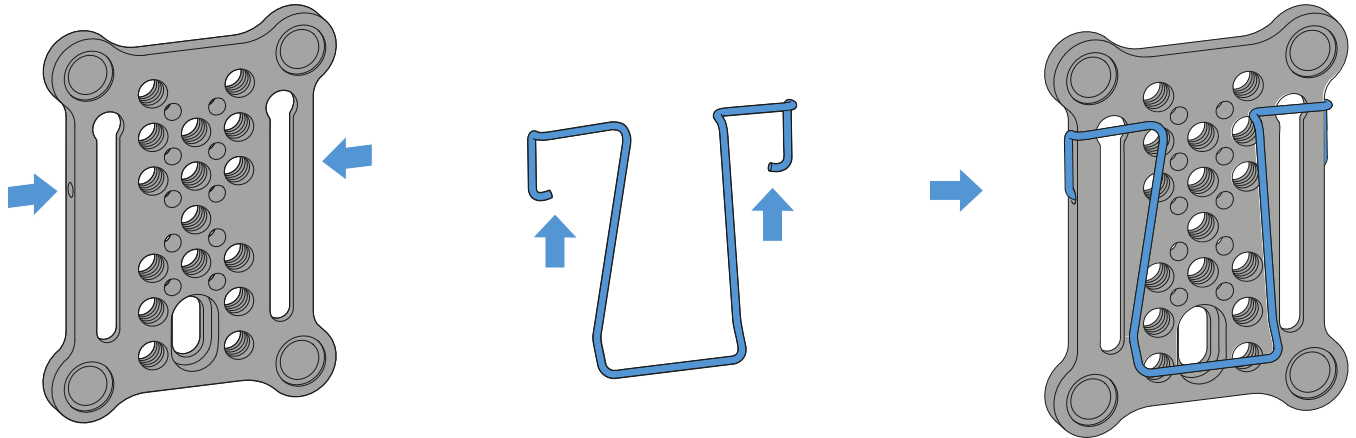

As an alternative to the hot shoe adapter, a **metal clip** can be attached to the side of the mounting plate.

To mount the clip on the mounting plate:

- ▷ Insert the clip into the side of the mounting plate as shown. This enables you to attach the receiver to belts or pockets using the mounting plate.



Mounting/stacking receivers on the mounting plate:

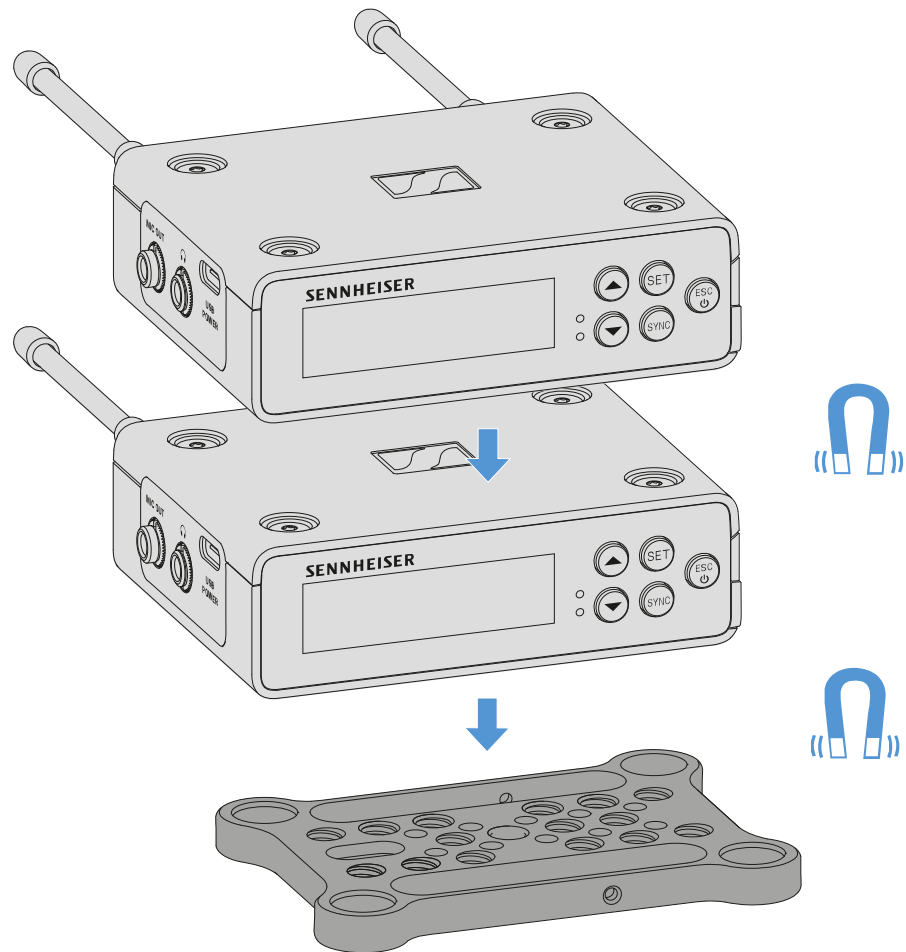

The receiver has magnets on the bottom, which means you can simply place it on the mounting plate without the need for an additional screw connection. This allows you to stack two receivers on top of one another.

To mount the receiver on the mounting plate:

- ▷ Insert the receiver's four magnetic feet into the recesses on the mounting plate.

Two stacked receivers can be connected to one another using a Y-cable. See "Cables for EW-DP EK"



Mounting with the mounting plate in a rotated position:

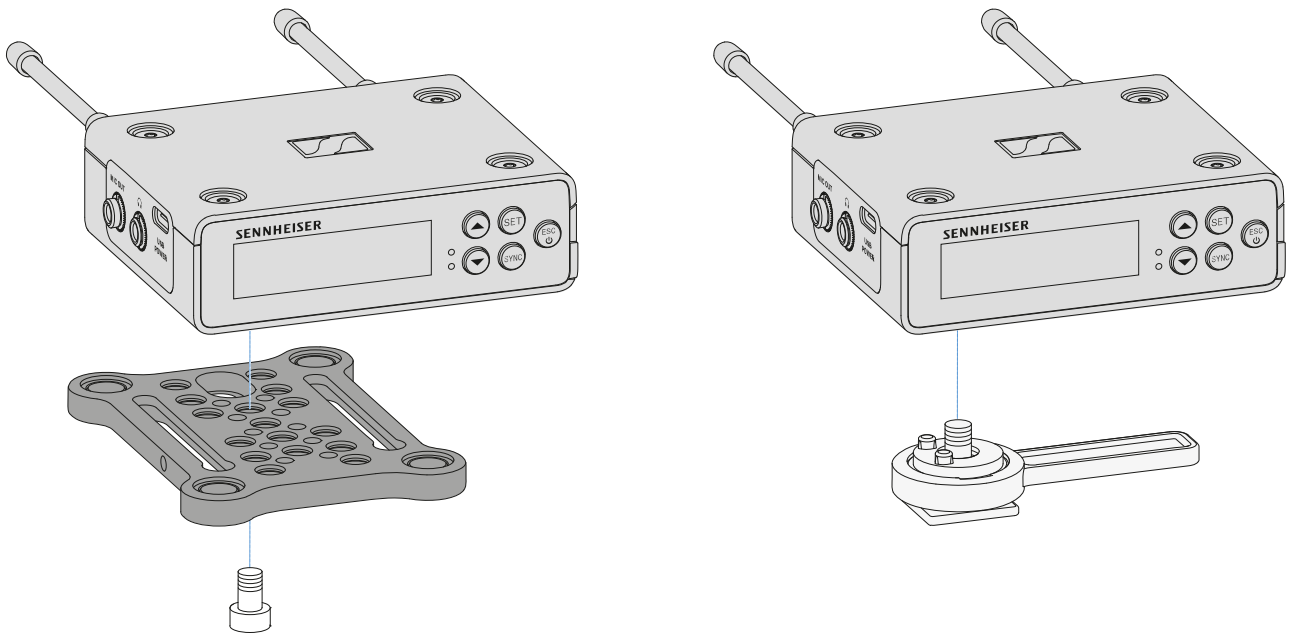

To mount the receiver with the mounting plate rotated by 90°:

- ▷ Turn the mounting plate by 90° and screw it to the bottom of the receiver in the desired position.

This mounting variant is particularly suitable for attaching with a clip.

To mount the receiver without a mounting plate:

- ▷ Screw the hot shoe adapter directly to the bottom of the receiver.

It can now be attached to a camera's hot shoe.



Example for mounting on a DSLR or video camera:

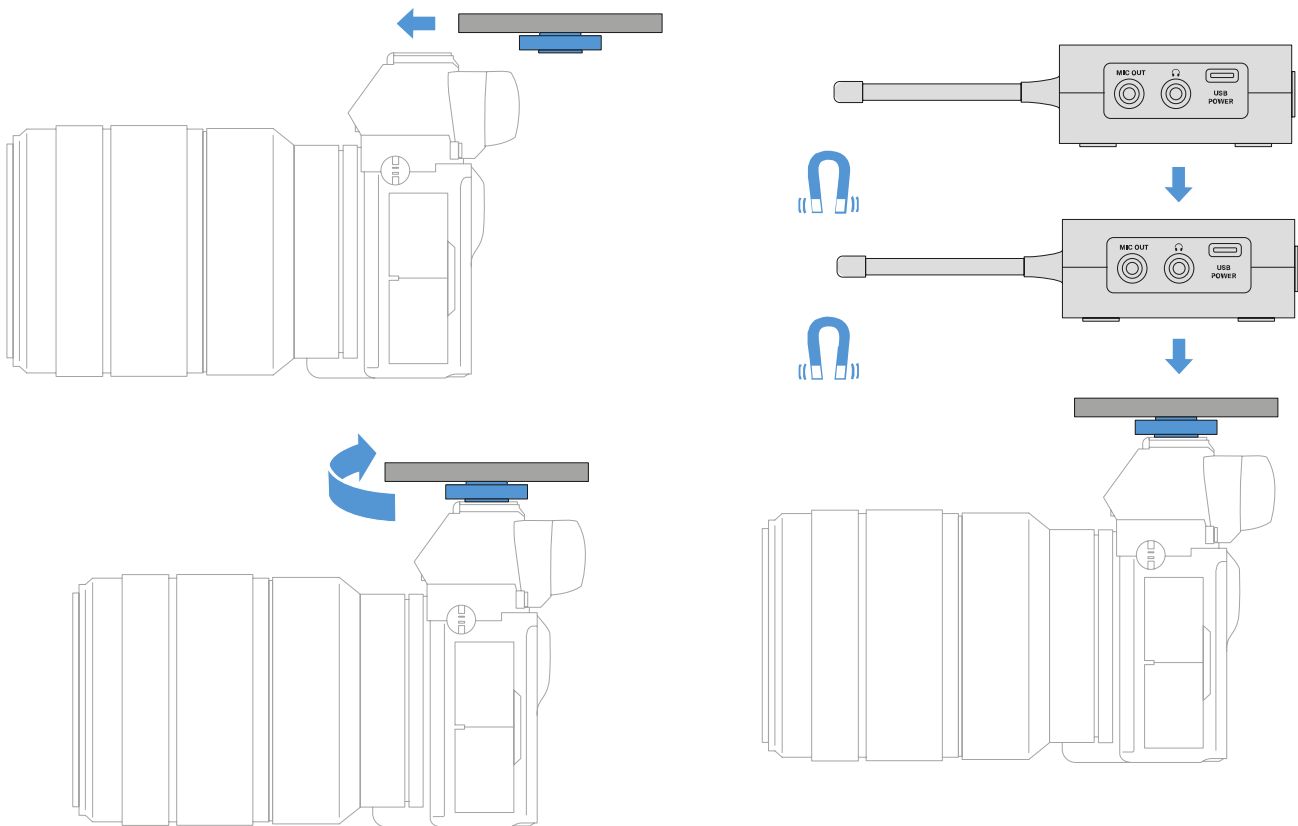

To mount the mounting plate with hot shoe adapter on a [DSLR or video camera](#):

- ▷ Slide the adapter into the camera's hot shoe.
- ▷ Rotate the lever on the hot shoe adapter until the adapter is tightly attached.

Now you can attach one or two receivers to the mounting plate.



Example for mounting on camera cages:

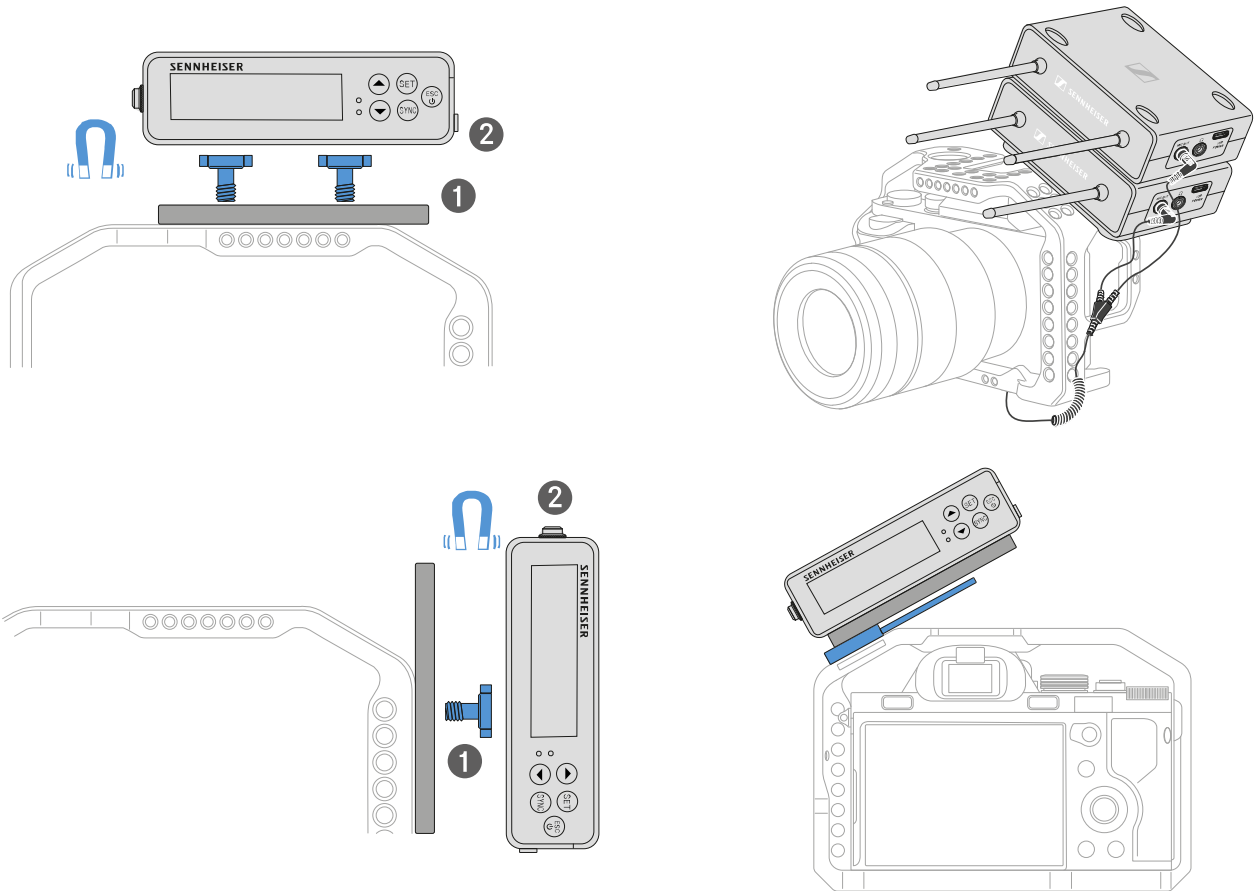

To attach the mounting plate to a **camera cage**:

- ▷ Screw the mounting plate to the camera cage using one or two screws, depending on the mounting situation and position.
- ▷ Attach the receiver to the mounting plate.



Example for attaching to pockets and belts:

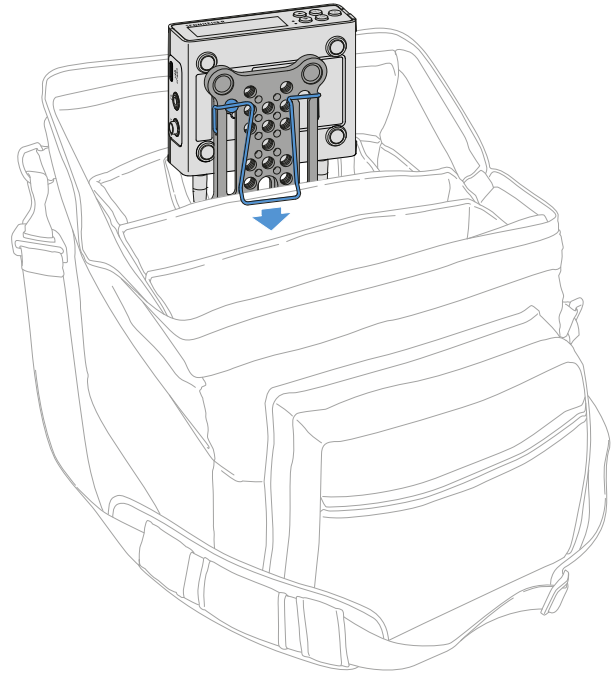
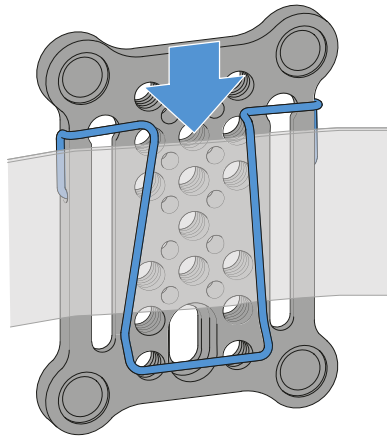
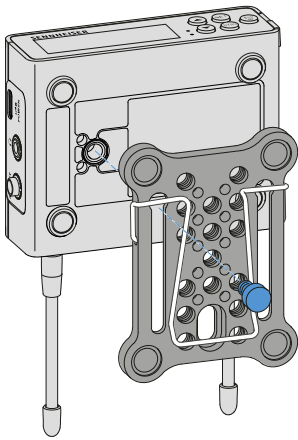

To fasten the receiver with mounting plate to **pockets or belts**:

- ▷ Attach the clip to the mounting plate.
- ▷ Attach the mounting plate to the receiver by inserting a screw through the slot.

You can now clip the receiver to belts or pockets.



Example for mounting on tripods:

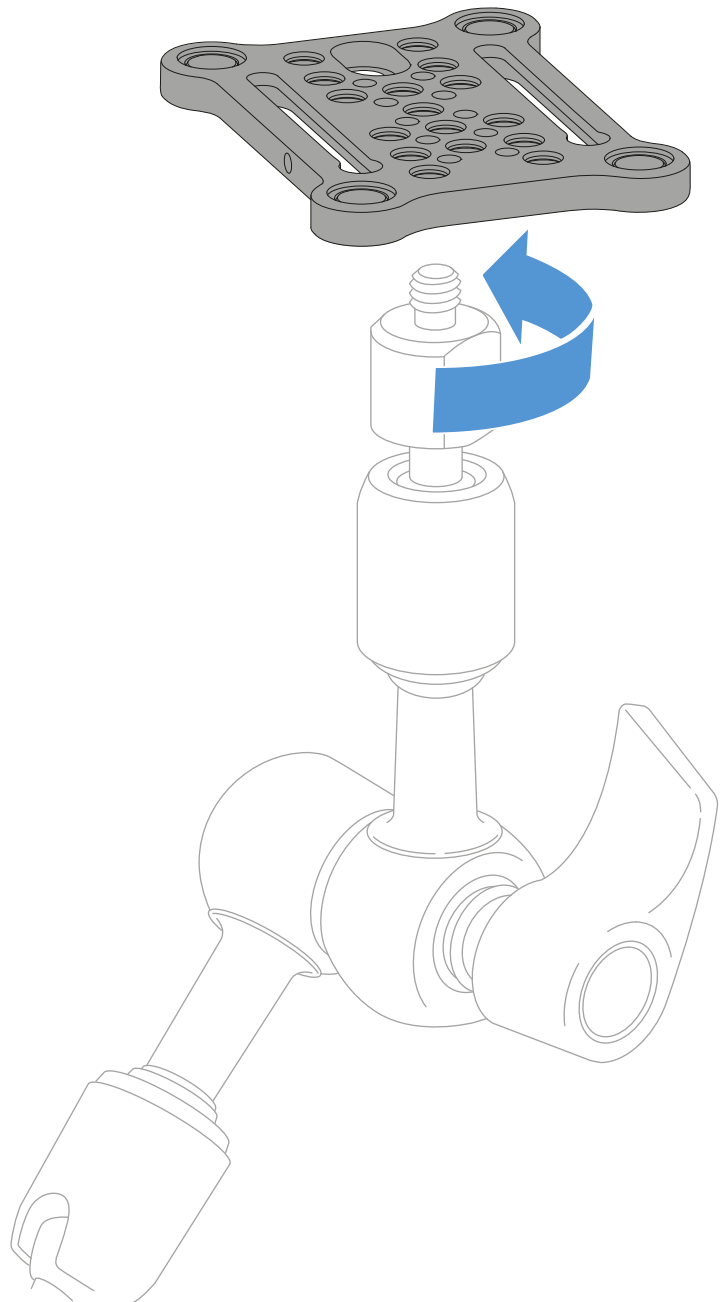

To fasten the mounting plate to a **tripod**:

- ▷ Screw the mounting plate onto the tripod thread at the desired position.

Now you can attach one or two receivers to the mounting plate.



Switching the receiver on and off

To switch the receiver **on**:

- ▶ Short-press the **ON/OFF** button.
The receiver switches on.

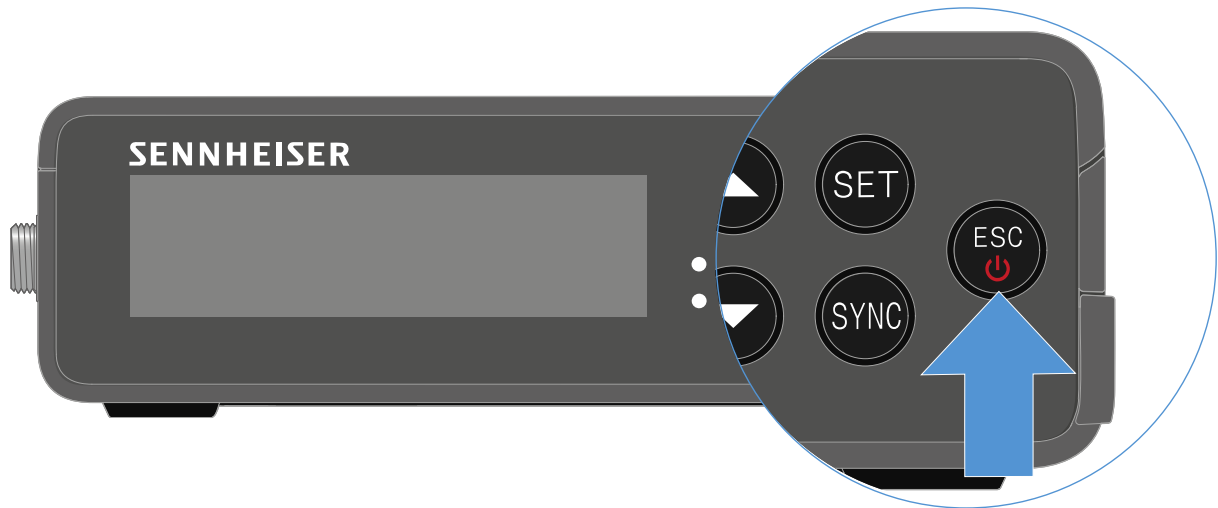

To switch the receiver **off**:

- ▶ Press the **ON/OFF** button.
- ▶ The receiver switches off.



Meaning of the LEDs

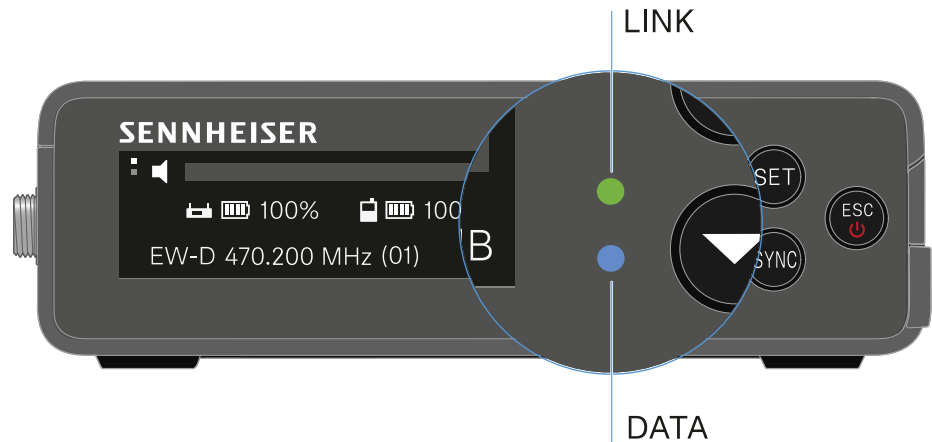

The **LINK** and **DATA** LEDs on the front of the receiver can indicate the following information.

LINK LED

The **LINK** LED provides information about the status of the radio link between the transmitter and receiver, as well as status information for the paired transmitter.

The LED is green:

- ▷ The link between the transmitter and receiver is established.
- ▷ The audio signal is active.

The LED is yellow:

- ▷ The link between the transmitter and receiver is established.
- ▷ The audio signal is muted.
or
- ▷ No microphone module is mounted on the SKM-S handheld transmitter.

The LED is flashing yellow:

- ▷ The link between the transmitter and receiver is established.
- ▷ The audio signal is overdriven (clipping).



The LED is continuously red:

- ▷ No link between the transmitter and receiver.
-

The LED is flashing red:

- ▷ The battery/rechargeable battery in the paired transmitter is low.
-

DATA LED

The **DATA** LED provides information on the receiver's **Bluetooth Low Energy** link to the **EW-D Smart Assist** app and on the synchronization of transmitters and receivers.

The LED is flashing blue:

- ▷ The **Bluetooth Low Energy** link is being established between the receiver and a smartphone or tablet with the **EW-D Smart Assist** app.
 - or
 - ▷ The receiver is being synchronized with a transmitter.
-

The LED is continuously blue:

- ▷ The firmware is being updated.
-

The LED is off:

- ▷ Normal operation
- ▷ There is currently no active data link.



Displays on the receiver's display panel

Status information such as frequency, reception quality, battery status and audio level is shown on the display.

The display also shows the operating menu, which you can use to configure all of the settings (see "Making settings in the menu").

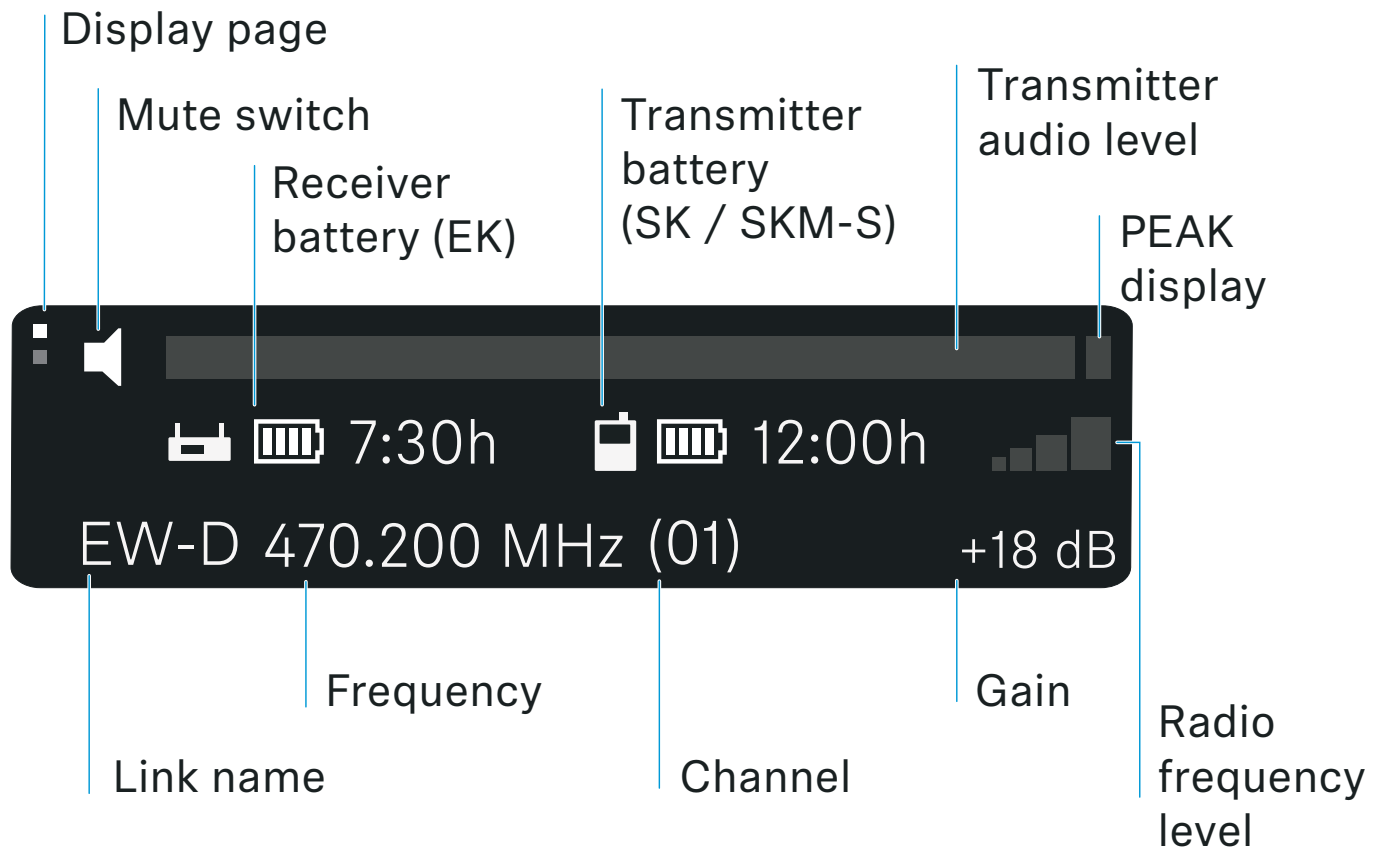

Further information

Display page:

"Main view and advanced view"

Mute / mute switch:

"MUTE switch menu item" | "Muting the handheld transmitter"
| "Muting the bodypack transmitter"

**Link name:**

Can be changed in the Smart Assist app.

Receiver battery:

"Power supply"

Transmitter battery:

SKM-S -> "Inserting and removing the batteries/rechargeable batteries" | SK -> "Inserting and removing the batteries/rechargeable batteries"

Frequency / channel:

"AUTO SCAN menu item" | "CHANNEL menu item"

Gain / transmitter audio level / PEAK indicator:

"GAIN menu item"

Radio frequency level:

"Establishing a radio link | Synchronizing the receiver and transmitter"



Making settings in the menu

Buttons for navigating the menu

Use the following buttons to navigate through the receiver's operating menu.

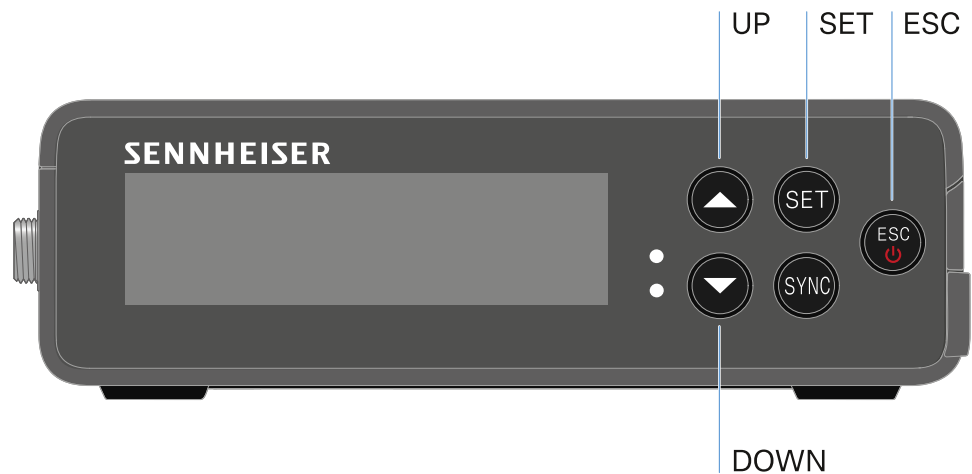

Press the **SET** button

- Open the menu
- Save settings in a menu item

Press the **UP** or **DOWN** button

- Changes to the previous or next menu item
- Changes the setting of a menu item

Press the **ESC** button

- Cancel input
-



Main view and advanced view

After the device switches on, the display shows the main view.

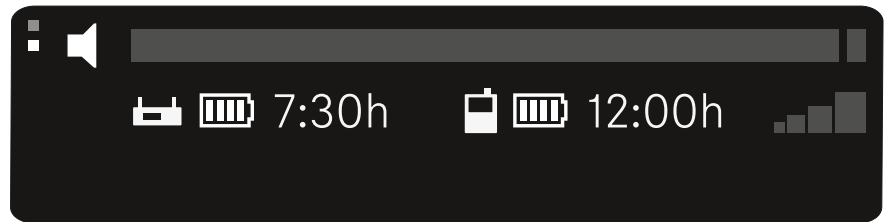

See "Displays on the receiver's display panel"

- ▷ Press the **UP** button to access the advanced view.

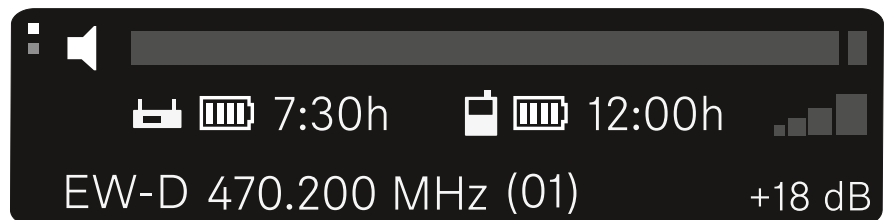

See "Displays on the receiver's display panel"

Opening the menu and navigating the menu items

To open the main menu:

- ▷ Press the **SET** button.

The first menu item **GAIN** appears in the display.



To navigate the menu items:

- ▷ Press the **UP** and **DOWN** buttons.

The currently active menu item appears in the display.



To open a menu item:

- ▷ Navigate to the desired menu item until it flashes.
- ▷ Press the **SET** button to open the selected menu item.

GAIN menu item

Under the **GAIN** menu item, you can set the level of the audio signal coming from the paired transmitter.

- ▷ Open the **GAIN** menu item.
The display looks as follows.

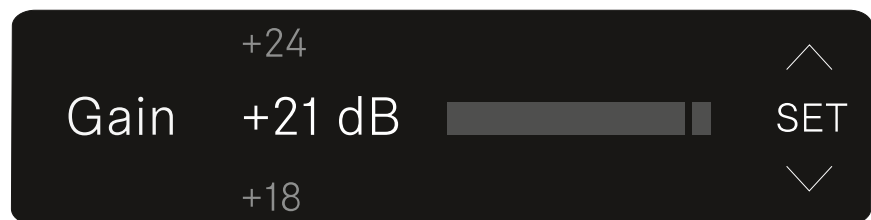

- ▷ Press the **UP** or **DOWN** button to adjust the value.
- ▷ Press the **SET** button to save the set value. You will then be returned to the main view or advanced view.

Output level menu item

Under the **Output level** menu item, you can set the level of the audio signal coming from the receiver's audio outputs. This audio signal can be output to a camera input or a mixing console, for example.

- ▷ Open the **Output level** menu item.
The display looks as follows.

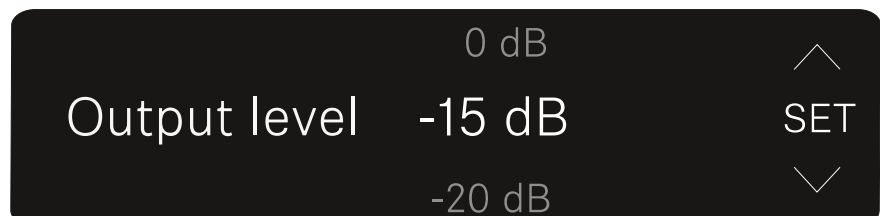

- ▷ Press the **UP** or **DOWN** button to adjust the value.
- ▷ Press the **SET** button to save the set value. You will then be returned to the main view or advanced view.



Headphone menu item

Under the **Headphone** menu item, you can set the volume of the audio signal coming from the receiver's headphone output.

CAUTION

Danger due to high volume levels

Volume levels that are too high may damage your hearing.

- ▷ Turn down the volume of the headphone output before you put on the headphone. Recommended impedance for headphones (HD 25 = 70 ohms). For headphones with < 32 ohms of impedance, the audio signal can be very loud at the lowest volume setting.

-
- ▷ Open the **Headphone** menu item.
The display looks as follows.

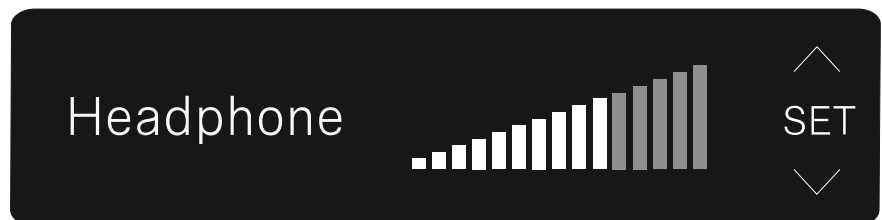

- ▷ Press the **UP** or **DOWN** button to adjust the value.
- ▷ Press the **SET** button to save the set value. You will then be returned to the main view or advanced view.



MUTE switch menu item

Under the **MUTE switch** menu item, you can disable the mute switch on the paired transmitter.

The transmitter can then no longer be muted.

- ▷ Open the **MUTE switch** menu item.
The display looks as follows.

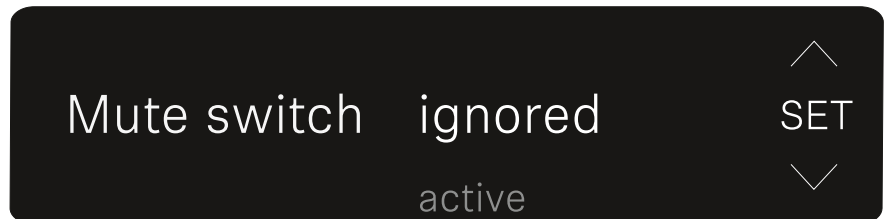

- ▷ Press the **UP** or **DOWN** button to enable (active) or disable (ignored) the function.
- ▷ Press the **SET** button to save the set value. You will then be returned to the main view or advanced view.

If a loudspeaker icon within a border appears on the upper left of the display, the transmitter's mute switch is disabled.

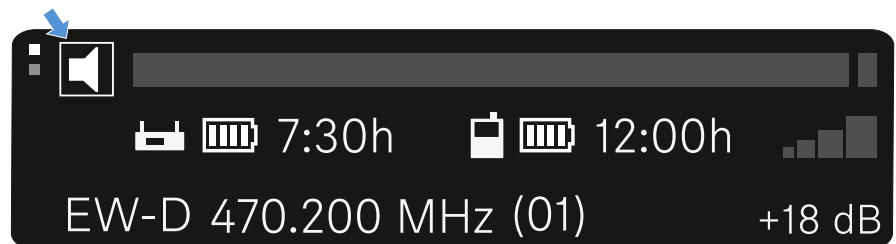



AUTO SCAN menu item

Under the **AUTO SCAN** menu item, you can perform an automatic frequency scan of your area. This enables you to easily find and assign free radio frequencies.

The scan starts at the lowest frequency in the device's frequency range.

- ▷ Open the **AUTO SCAN** menu item.
The scan starts automatically. The next free frequency is shown on the display.

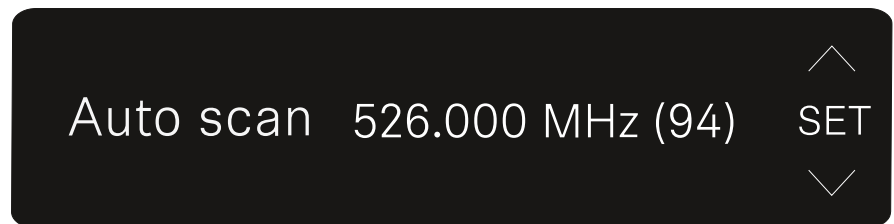

- ▷ Press the **SET** button to accept the displayed frequency. You will then be returned to the main view or advanced view.
or
- ▷ Press the **UP** or **DOWN** button to display the next free frequency above or below the current frequency.
or
- ▷ Press the **ESC** button to cancel the scan.
The previous frequency remains unchanged.

If you have set a new frequency, you must still **synchronize** the **receiver** with the **transmitter** to establish the radio link (see "Establishing a radio link | Synchronizing the receiver and transmitter").



CHANNEL menu item

Under the **CHANNEL** menu item, you can set the radio frequency by selecting a preset channel.

If you are not sure whether the selected frequency is free, we recommend performing a scan to detect all free frequencies: "AUTO SCAN menu item".

- ▷ Open the **CHANNEL** menu item.
The display looks as follows.

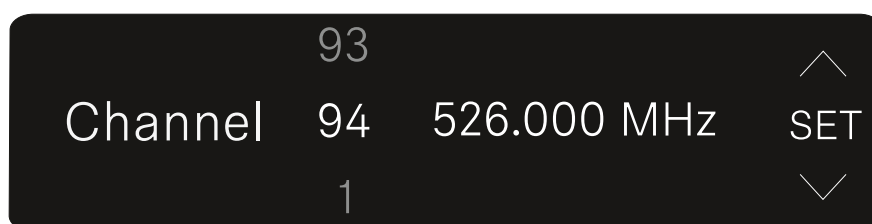

- ▷ Press the **UP** or **DOWN** button to select a preset channel.
- ▷ Press the **SET** button to accept the displayed frequency. You will then be returned to the main view or advanced view.

or

- ▷ Press the **ESC** button to cancel the setting.

The previous frequency remains unchanged.

If you have set a new frequency, you must still **synchronize** the **receiver** with the **transmitter** to establish the radio link (see "Establishing a radio link | Synchronizing the receiver and transmitter").



Frequency menu item

Under the **FREQUENCY** menu item, you can manually set the radio frequency independently of the preset channels.

If you are not sure whether the selected frequency is free, we recommend performing a scan to detect all free frequencies: "AUTO SCAN menu item".

- ▷ Open the **FREQUENCY** menu item.
The display looks as follows.

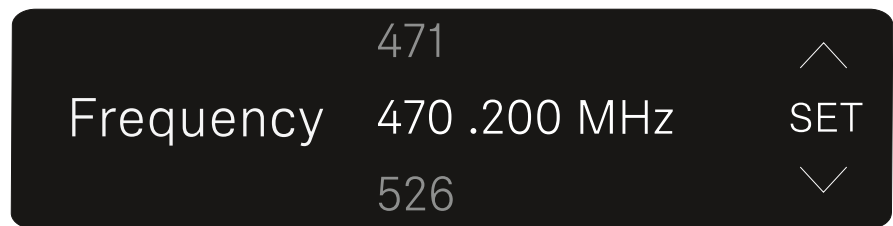

- ▷ Press the **UP** or **DOWN** button to set the frequency in the megahertz range.
 - ▷ Press the **SET** button to select the value and activate fine-tuning of the frequency in the kilohertz range.
 - ▷ Press the **UP** or **DOWN** buttons to finely adjust the frequency in the kilohertz range.
 - ▷ Press the **SET** button to accept the displayed frequency. You will then be returned to the main view or advanced view.
- or
- ▷ Press the **ESC** button to cancel the setting.
The previous frequency remains unchanged.

If you have set a new frequency, you must still **synchronize** the **receiver** with the **transmitter** to establish the radio link (see "Establishing a radio link | Synchronizing the receiver and transmitter").



BRIGHTNESS menu item

Under the **BRIGHTNESS** menu item, you can set the brightness of the display.

- ▷ Open the **BRIGHTNESS** menu item.
The display looks as follows.

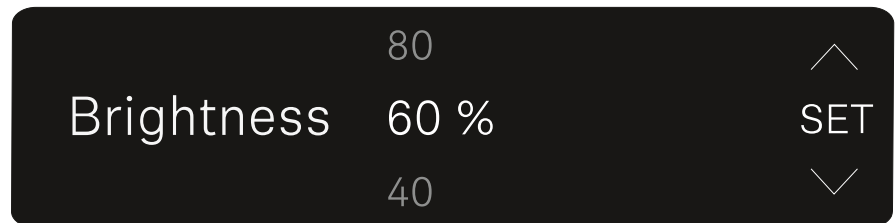

- ▷ Press the **UP** or **DOWN** button to set the desired brightness.
- ▷ Press the **SET** button to save the set value. You will then be returned to the main view or advanced view.

RESET menu item

Under the **RESET** menu item, you can reset the receiver to its factory settings.

- ▷ Open the **RESET** menu item.
The display looks as follows.

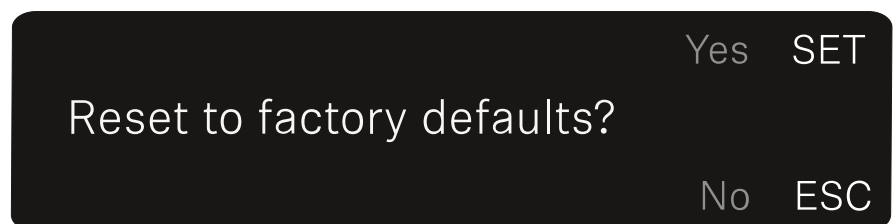



- ▷ Press the **SET** or **ESC** button to switch between the options **YES** and **NO**.
YES: The receiver is reset to its factory settings.
NO: The receiver is not reset.
- ▷ You will then be returned to the main view or advanced view.



Establishing a radio link | Synchronizing the receiver and transmitter

Information on compatibility between EW-D, EW-DX and EW-DP

	EW-D EM	EW-DX EM 2	EW-DP EK
EW-D SKM-S  EW-D SK			
EW-DX SKM EW-DX SKM-S  EW-DX SK EW-DX SK 3-PIN			

 The transmitter and the receiver are fully compatible with each other.

 The transmitter and the receiver are compatible with each other. Some features may not be available.

Conditions and restrictions for using frequencies

There may be special conditions and restrictions for using frequencies in your country.

Before putting the product into operation, find the information for your country at the following address:

www.sennheiser.com/sifa



Connecting to the EW-D EM receiver / synchronizing the EW-D EM

To establish a radio link between the transmitter and receiver, we recommend the following procedure.

In order to establish a connection between a receiver and transmitters of the EW-D series, the devices must always be synchronized with each other.

To successfully connect a receiver and a transmitter, both devices must have the same frequency range.

Step 1: Set a free frequency

We recommend using the **AUTO SCAN** function, as this is the most reliable way to identify free frequencies (see "AUTO SCAN menu item").

If you know free frequencies in your area, you can also set the frequency manually (see "CHANNEL menu item" or "TUNE menu item").

Step 2: Pairing a receiver with a transmitter

- ▷ Short-press the **SYNC** button on the receiver.
The blue **DATA** LED flashes.



- ▷ Short-press the **SYNC** button on the transmitter.
The blue **DATA** LED flashes.

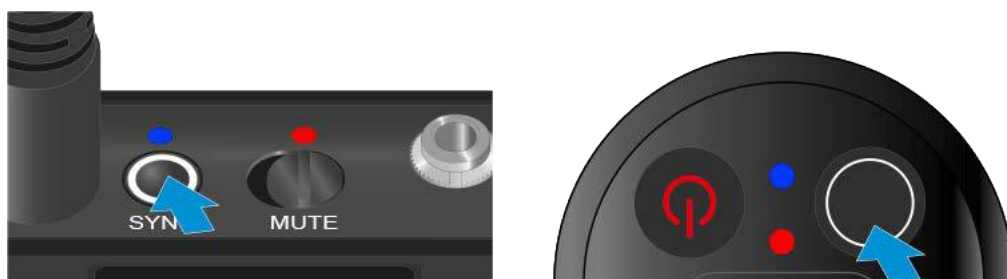

The transmitter and receiver will be paired. Once the link is established, the **LINK** LED on both units will light up green.

Be sure to press the **SYNC** button on all devices only briefly (less than 2 seconds). Holding the **SYNC** button longer than this will start the firmware update mode and cancel the synchronization process.



Connecting to the EW-DX EM 2 receiver / synchronizing the EW-DX EM 2

To establish a radio link between the transmitter and receiver, we recommend the following procedure.

In order to establish a connection between a receiver and transmitters of the EW-D series, the devices do not necessarily have to be synchronized with each other.

To successfully connect a receiver and a transmitter, both devices must have the same frequency range.

Set a free frequency

We recommend using the **Auto Setup** function, as this is the most reliable way to identify free frequencies (see "Ch 1 / Ch 2 -> Scan / Auto Setup menu item").

If you know free frequencies in your area, you can also set the frequency manually.

- ▷ EW-DX EM 2: "Ch 1 / Ch 2 -> Frequency menu item"
- ▷ EW-DX SKM(-S): "Making settings in the menu of the handheld transmitter"
- ▷ EW-DX SK (3-PIN): "Making settings in the menu of the bodypack transmitter"

Once you have set the same frequency for the desired receiving channel on the receiver and for the transmitter you want to connect, the radio link is established.

To ensure that all settings are transmitted to the transmitter, we recommend synchronizing the transmitter with the receiving channel.

Synchronizing the receiver and transmitter

To synchronize the receiver and the transmitter:

- ▷ On the receiver, press the **CH 1** or **CH 2** button to select the channel you want to synchronize.

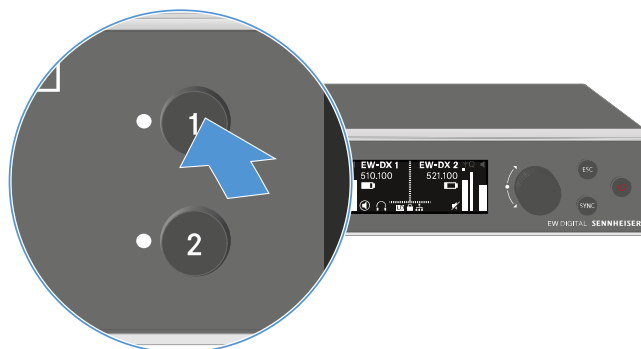

- ▷ Press the SYNC button on the receiver.

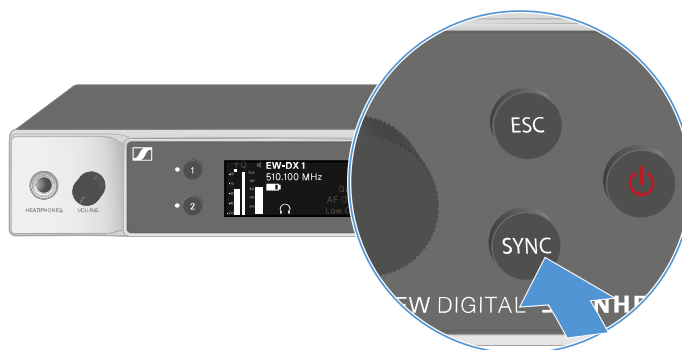

The receiver's display shows that the synchronization process has started.

The LED for the selected receiving channel flashes blue.

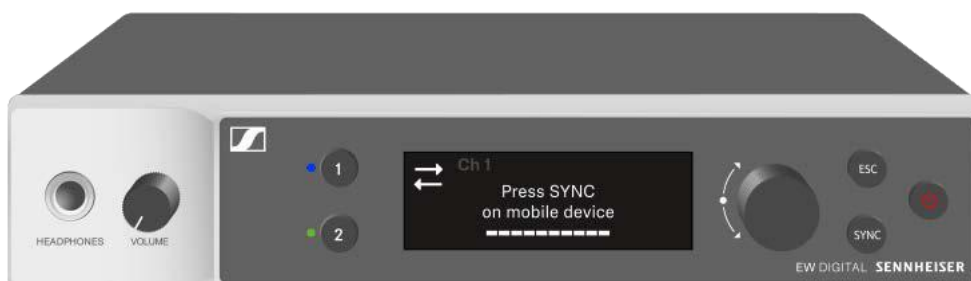

- ▶ Short-press the **SYNC** button on the transmitter. The blue **DATA** LED flashes.

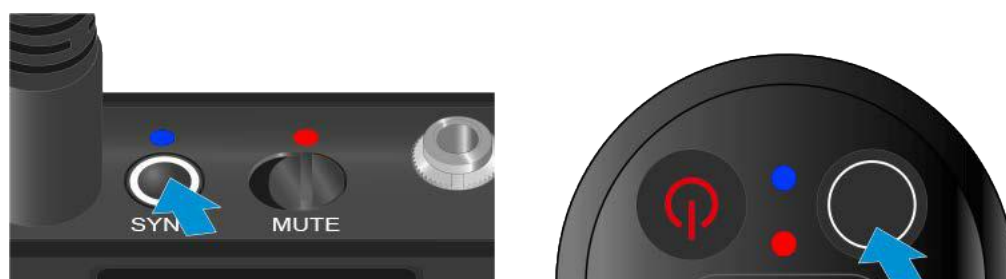

The transmitter and receiver will be synchronized.



Connecting to the EW-DP EK receiver / synchronizing the EW-DP EK

To establish a radio link between the transmitter and receiver, we recommend the following procedure.

In order to establish a connection between a receiver and transmitters of the EW-DP EK series, the devices must always be synchronized with each other.

To successfully connect receivers and transmitters, both devices must have the same frequency range.

Step 1: Set a free frequency

We recommend using the **AUTO SCAN** function, as this is the most reliable way to identify free frequencies (see "AUTO SCAN menu item").

If you know free frequencies in your area, you can also set the frequency manually (see "CHANNEL menu item" or "Frequency menu item").

Step 2: Pairing a receiver with a transmitter

- ▷ Short-press the **SYNC** button on the receiver.
The blue **DATA** LED flashes.

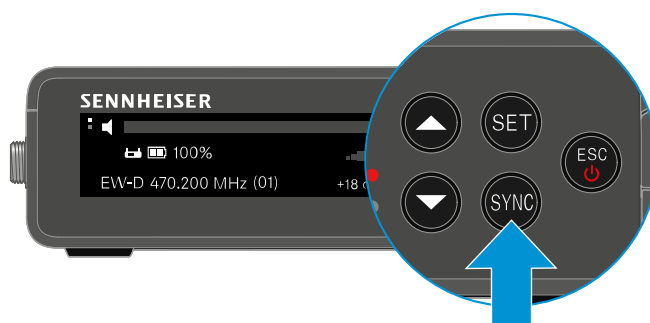

- ▷ Short-press the **SYNC** button on the transmitter.
The blue **DATA** LED flashes.

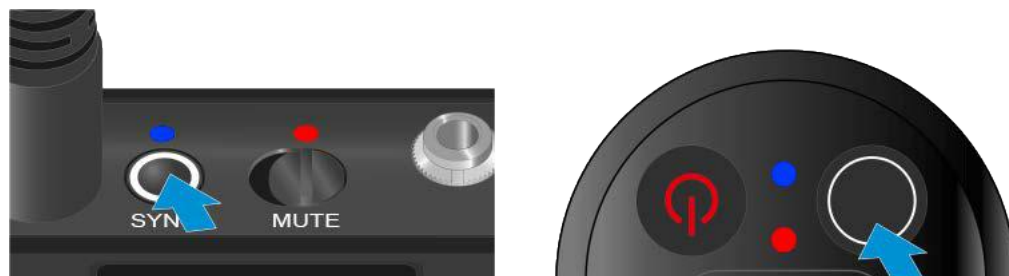

The transmitter and receiver will be paired. Once the link is established, the **LINK** LED on both units will light up green.

Be sure to press the **SYNC** button on all devices only briefly (less than 2 seconds). Holding the **SYNC** button longer than this will start the firmware update mode and cancel the synchronization process.



EW-DP EK portable receiver

Input voltage

~ 1.8 – 4.35 V

Input current

Typically < 250 mA / max. < 400 mA / max. < 750 mA
(2x AA batteries) < 300 mA @ 5 V (USB-C standalone)

Power supply

2x AA batteries 1.5 V or USB-C PD (max.):

- 5 V/1500 mA
- 9 V/900 mA
- 12 V/700 mA

Transmission power

BLE: max. 10 mW EIRP

Audio output power

< 2 dBV max. (high level) /
< 4 dBV max. (high level)

Headphone output

< 50 mW into 16 ohms

Dimensions

86 × 67 × 28 mm (1 3/4" × 3 7/8" × 7 3/16")

Weight

approx. 140 g