



Milan Series

600/1100 Watt 2 Way 10"/12"/15" Full Range Powered Loudspeaker with Klark Teknik DSP Technology for Portable PA and Installation Applications

2200 Watt 15"/18" Powered Subwoofer with Klark Teknik Technology for Portable PA and Installation Applications

Quick Start Guide



 **Turbosound**

EN Important Safety Instructions

Terminals marked with this symbol carry electrical current of sufficient magnitude to constitute risk of electric shock.

Use only high-quality professional speaker cables with ¼" TS or twist-locking plugs pre-installed. All other installation or modification should be performed only by qualified personnel.



This symbol, wherever it appears, alerts you to the presence of uninsulated dangerous voltage inside the enclosure - voltage that may be sufficient to constitute a risk of shock.



This symbol, wherever it appears, alerts you to important operating and maintenance instructions in the accompanying literature. Please read the manual.

**Caution**

To reduce the risk of electric shock, do not remove the top cover (or the rear section). No user serviceable parts inside. Refer servicing to qualified personnel.

**Caution**

To reduce the risk of fire or electric shock, do not expose this appliance to rain and moisture. The apparatus shall not be exposed to dripping or splashing liquids and no objects filled with liquids, such as vases, shall be placed on the apparatus.

**Caution**

These service instructions are for use by qualified service personnel only. To reduce the risk of electric shock do not perform any servicing other than that contained in the operation instructions. Repairs have to be performed by qualified service personnel.

1. Read these instructions.
2. Keep these instructions.
3. Heed all warnings.
4. Follow all instructions.
5. Do not use this apparatus near water.
6. Clean only with dry cloth.
7. Do not block any ventilation openings. Install in accordance with the manufacturer's instructions.
8. Do not install near any heat sources such as radiators, heat registers, stoves, or other apparatus (including amplifiers) that produce heat.

9. Do not defeat the safety purpose of the polarized or grounding-type plug. A polarized plug has two blades with one wider than the other. A grounding-type plug has two blades and a third grounding prong. The wide blade or the third prong are provided for your safety. If the provided plug does not fit into your outlet, consult an electrician for replacement of the obsolete outlet.

10. Protect the power cord from being walked on or pinched particularly at plugs, convenience receptacles, and the point where they exit from the apparatus.

11. Use only attachments/accessories specified by the manufacturer.



12. Use only with the cart, stand, tripod, bracket, or table specified by the manufacturer, or sold with the apparatus. When a cart is used, use caution when moving the cart/apparatus combination to avoid

injury from tip-over.

13. Unplug this apparatus during lightning storms or when unused for long periods of time.

14. Refer all servicing to qualified service personnel. Servicing is required when the apparatus has been damaged in any way, such as power supply cord or plug is damaged, liquid has been spilled or objects have fallen into the apparatus, the apparatus has been exposed to rain or moisture, does not operate normally, or has been dropped.

15. The apparatus shall be connected to a MAINS socket outlet with a protective earthing connection.

16. Where the MAINS plug or an appliance coupler is used as the disconnect device, the disconnect device shall remain readily operable.



17. Correct disposal of this product: This symbol indicates that this product must not be disposed of with household waste, according to the WEEE Directive (2012/19/EU) and your national law. This product should be taken

to a collection center licensed for the recycling of waste electrical and electronic equipment (EEE). The mishandling of this type of waste could have a possible negative impact on the environment and human health due to potentially hazardous substances that are generally associated with EEE. At the same time, your cooperation in the correct disposal of this product will contribute to the efficient use of natural resources. For more information about where you can take your waste equipment for recycling, please contact your local city office, or your household waste collection service.

LEGAL DISCLAIMER

Music Group accepts no liability for any loss which may be suffered by any person who relies either wholly or in part upon any description, photograph, or statement contained herein. Technical specifications, appearances and other information are subject to change without notice. All trademarks are the property of their respective owners. Midas, Klark Teknik, Lab Gruppen, Lake, Tannoy, Turbosound, TC Electronic, TC Helicon, Behringer, Bugera, DDA and TC Applied Technologies are trademarks or registered trademarks of Music Group IP Ltd. © Music Group IP Ltd. 2015 All rights reserved.

LIMITED WARRANTY

For the applicable warranty terms and conditions and additional information regarding Music Group's Limited Warranty, please see complete details online at music-group.com/warranty.

Milan Series Hook-up

Small duo setup with integrated mixer and Mix Out function

Montaje para un pequeño dúo con mezclador integrado y función Mix Out

Configuration pour duo utilisant la console de mixage intégrée et la fonction Mix Out

Kleines Duo-Setup mit integriertem Mischpult und Mix Out-Funktion

Instalação do par pequeno com misturador integrado e função Mix Out

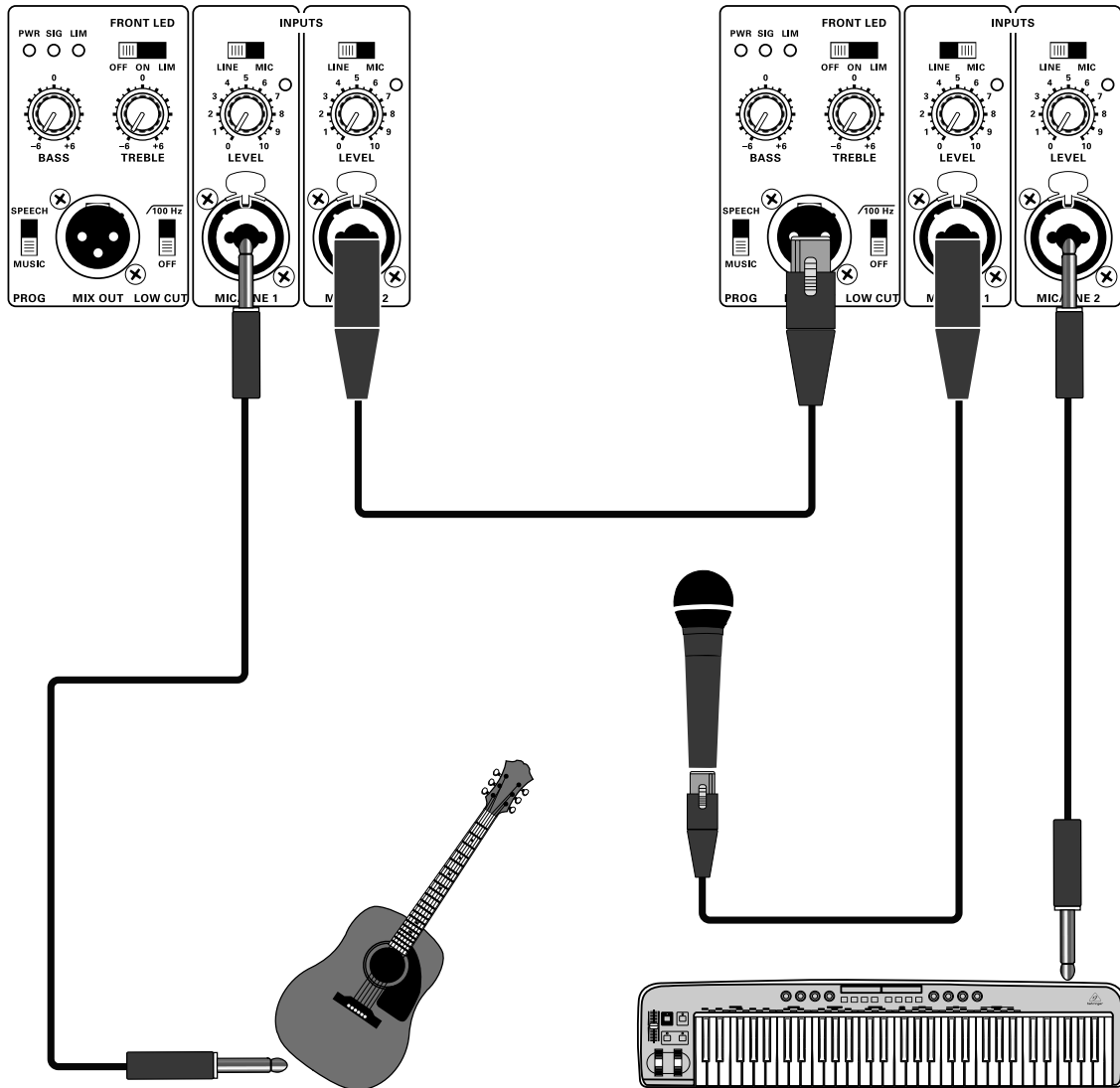

Stereo PA with an external mixer

PA stereo con un mezclador externo

Système de sonorisation stéréo avec console de mixage externe

Stereo-PA mit externem Mischpult

PA estéreo com um mistrurador externo

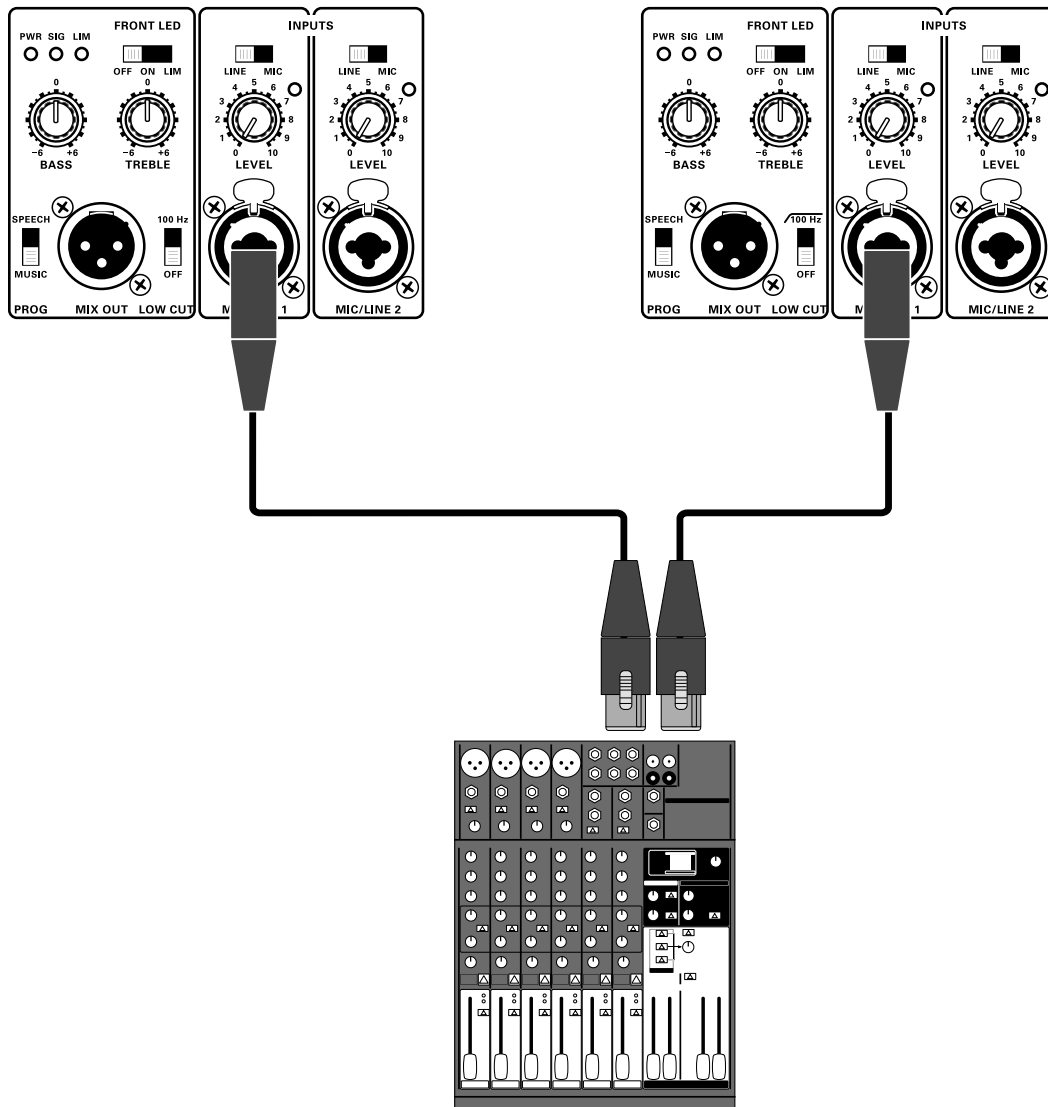

Milan Series Hook-up

Stereo PA with an external mixer and subwoofer(s)

PA stereo con un mezclador externo y subwoofer(s)

Système de sonorisation stéréo avec console de mixage externe et Subwoofer(s)

Stereo-PA mit externem Mischpult und Subwoofer(n)

PA estéreo com um misturador externo e subwoofer(s)

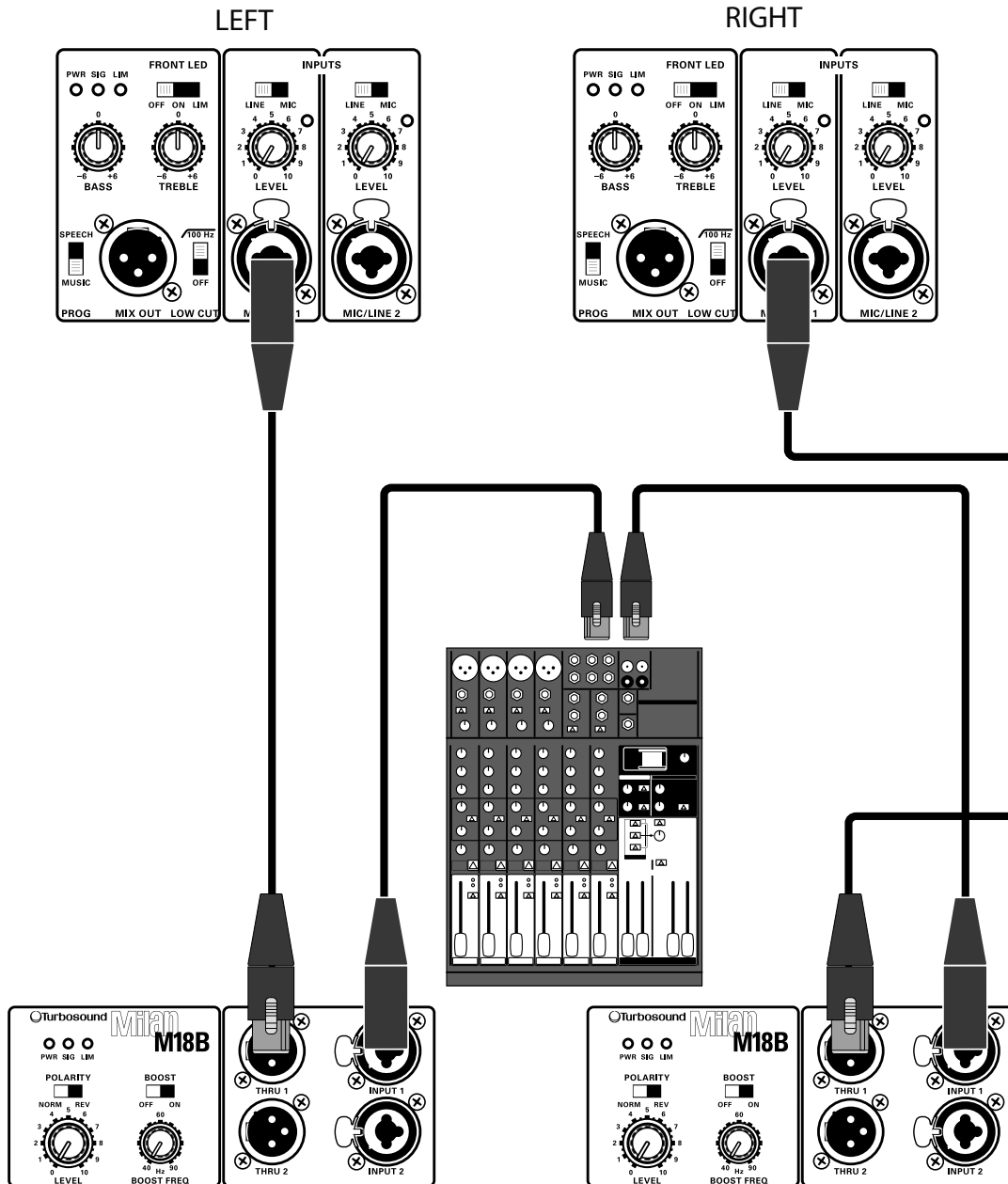

Stereo PA with powered wedge monitors

PA stereo con monitores auto-amplificados de tipo cuña

Système de sonorisation stéréo avec moniteurs de retour actifs

Stereo-PA mit aktiven Bodenmonitoren

PA estéreo com monitores de palco elétricos

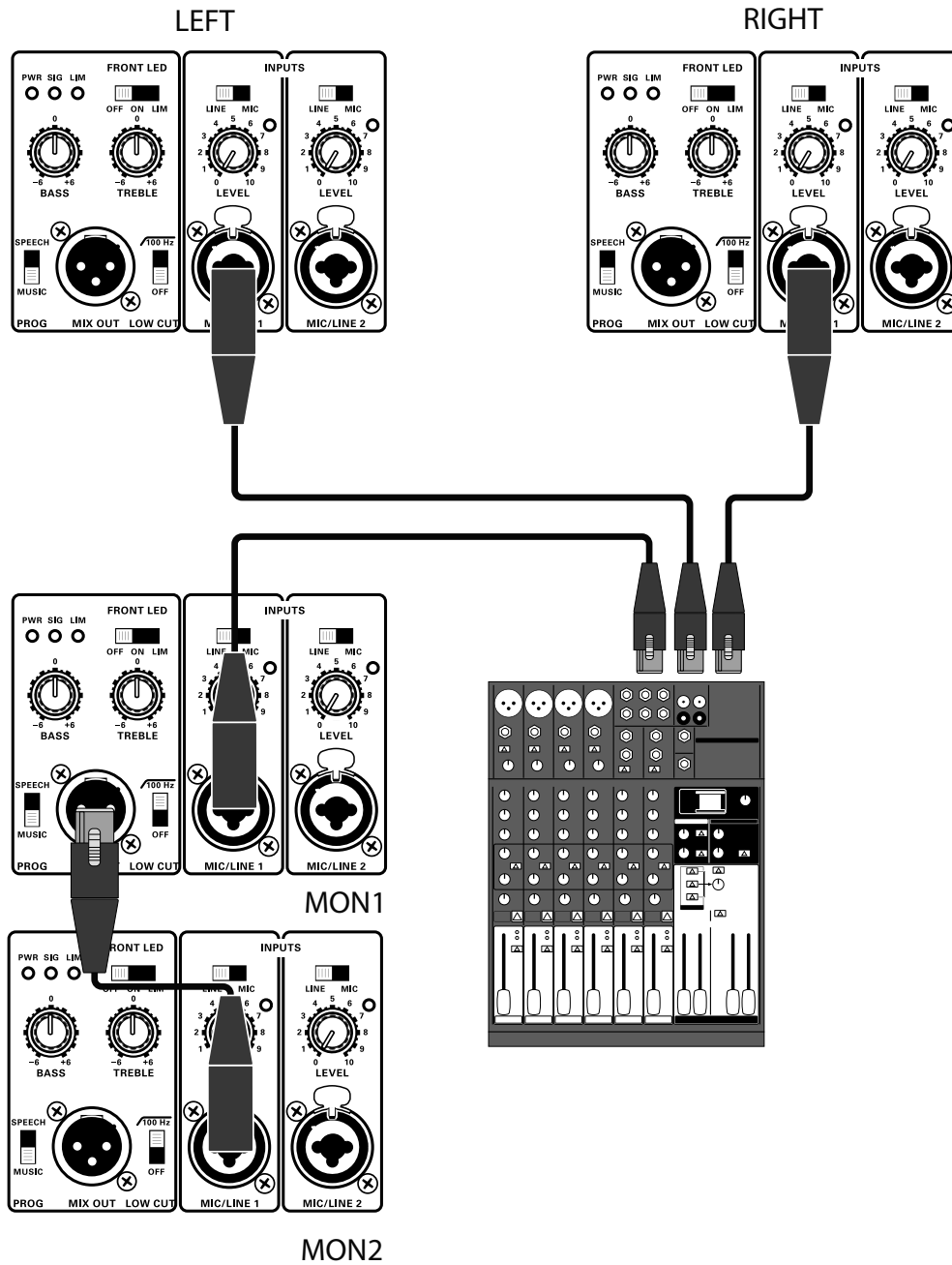

Milan Series Controls

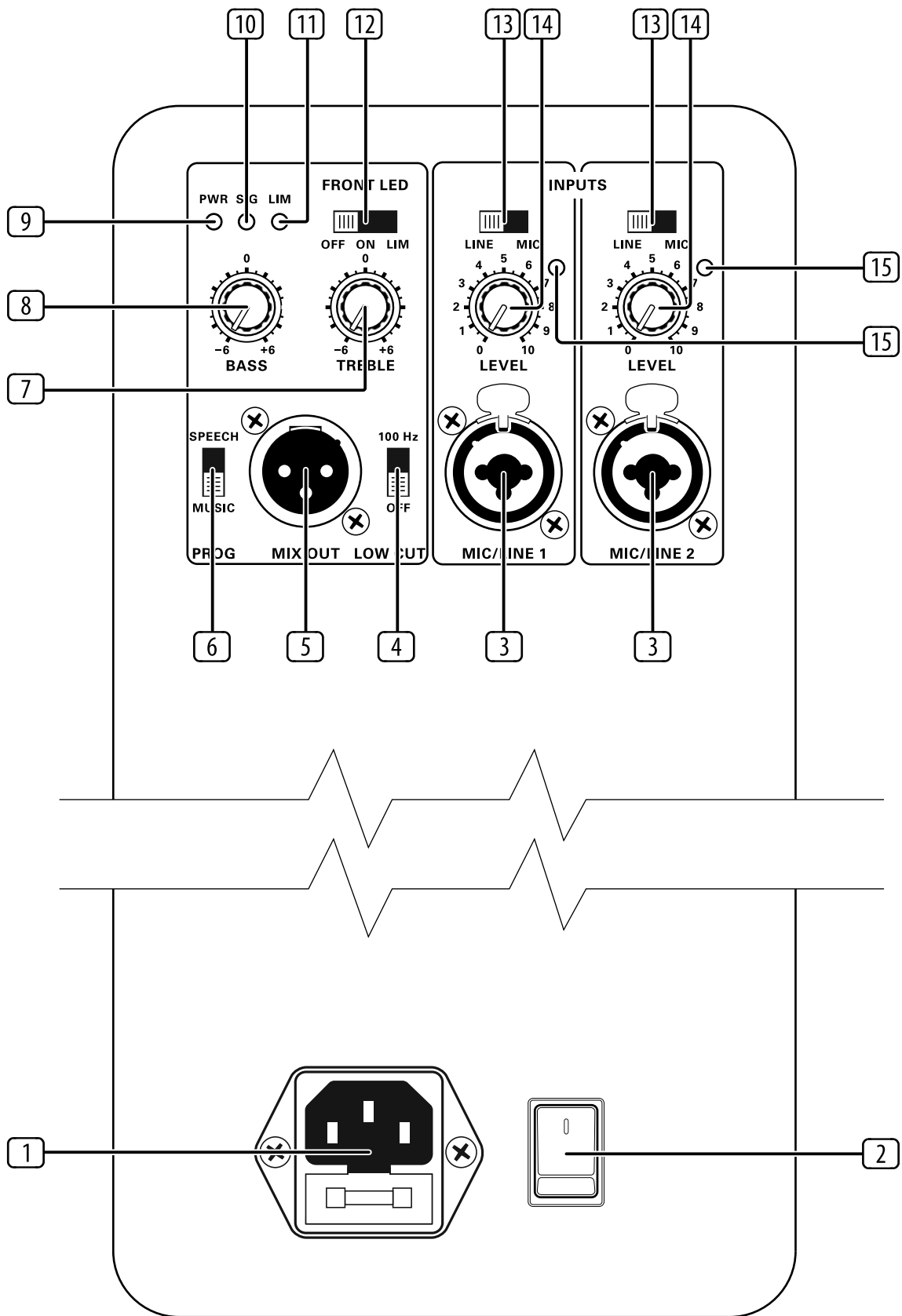

- 1 **Mains Connector and Fuseholder** – Mains power is connected to the loudspeaker via a combination IEC connector and fuseholder.
- 2 **Mains Switch** – Rocker switch turns mains power on to the loudspeaker.
- 3 **Signal Input** – These combo female XLR/jack connectors accept both XLR connectors and mono (2 pole) or stereo (3 pole) ¼" jack plugs.
- 4 **100 Hz Low Cut Switch** – This low cut filter can be switched in when using the Milan loudspeaker with subwoofers or when used as a floor monitor.
- 5 **Mix Out** – A balanced line level signal output on a balanced male XLR connector. This output contains a mix of all connected sources and is post-EQ, although this output is independent of the 100 Hz low cut switch.
- 6 **Program Switch** – Sets a frequency response contour optimised for either voices or mixed music program material.
- 7 **Treble Control** – The treble control provides ± 6 dB of shelving at 12 kHz.
- 8 **Bass Control** – The bass control provides ± 6 dB of shelving at 80 Hz.
- 9 **Power On Indicator** – Blue LED illuminates when mains power is applied to the loudspeaker and powered up via the rocker switch.
- 10 **Signal Indicator** – Illuminates green to indicate that input signal is present.
- 11 **Limit Indicator** – Illuminates red when the signal level approaches maximum and the limiters start working.
- 12 **Front LED Status** – The function of the illuminated front badge can be toggled between permanently on, permanently off, or to indicate action of the limiting circuits.
- 13 **Mic / Line Switch** – Selects the input for that channel to accept either a low level, low impedance microphone, or a high level, high impedance source such as a mixing console, keyboard or acoustic instrument with onboard electrics.
- 14 **Level Control** – Rotary level control which attenuates the input signal level of the connected instrument / line source for that input channel.
- 15 **Clip Indicator** – Illuminates red if the input signal ahead of the gain control is too high and is clipping the input.

Milan Series Controls

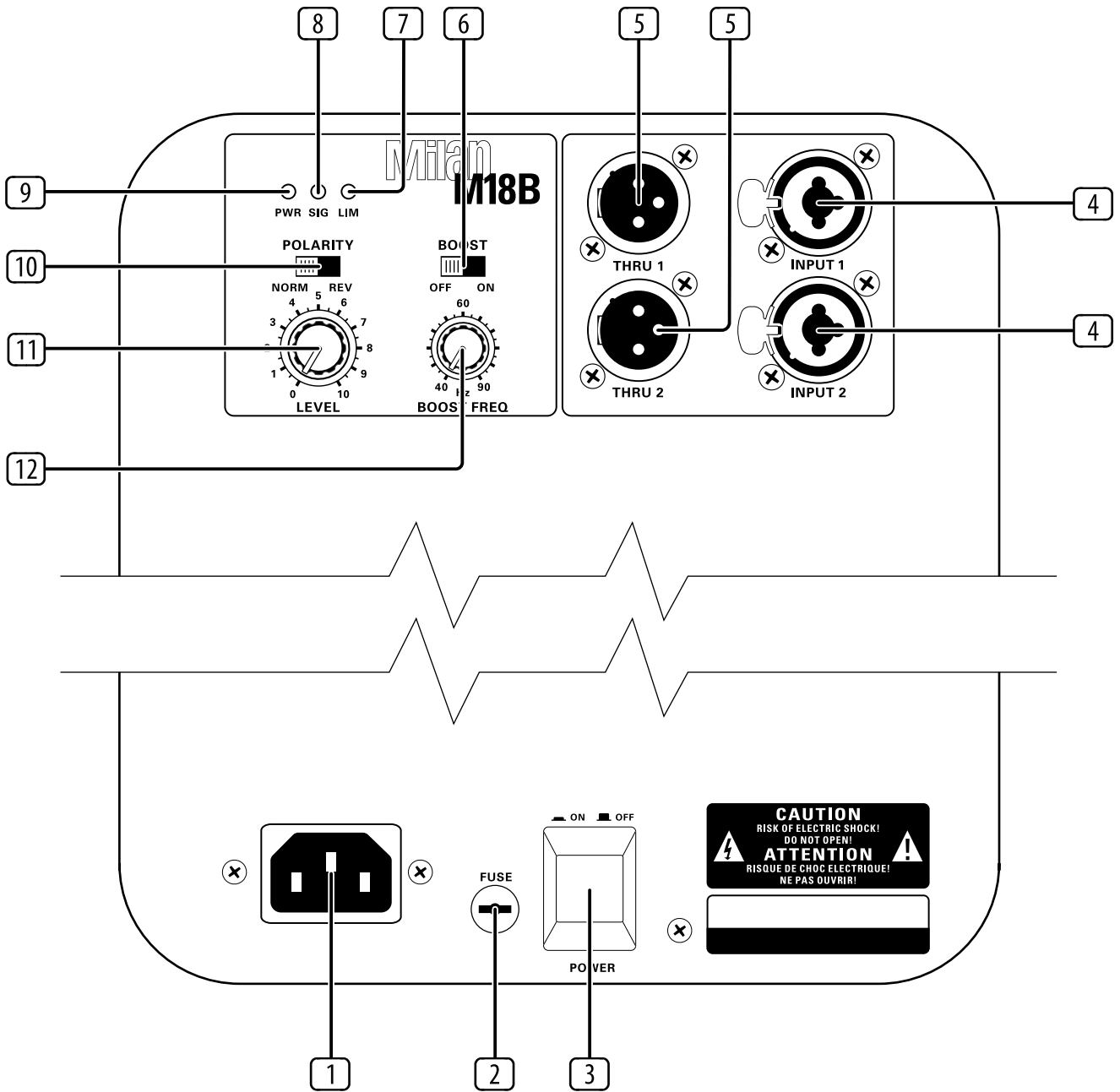

- 1 **Mains Connector** – Mains power is connected to the subwoofer via an IEC connector.
- 2 **Fuseholder** – Replace fuse only with the same type and rating.
- 3 **Mains Switch** – Toggle push switch turns mains power on to the loudspeaker. Make sure the level control is fully off (MIN) before switching on.
- 4 **Inputs** – These combo female XLR/jack connectors accept both 3-pin XLR connectors and mono (2 pole) or stereo (3 pole) ¼" jack plugs for connection to balanced or unbalanced mixing console outputs.
- 5 **Thru Connections** – These 3-pin balanced male XLR connectors provide independent full range audio signals from each input channel for loop-through connections to Milan two-way loudspeakers or additional Milan subwoofers.
- 6 **Boost** – Applies +6 dB of boost with a Q factor of 1 at a centre frequency selected via the associated boost freq control (12).
- 7 **Limit Indicator** – Illuminates red when the signal level approaches maximum and the limiters start working.
- 8 **Signal Indicator** – Illuminates green to indicate that input signal is present.
- 9 **Power On Indicator** – Blue LED illuminates when mains power is applied to the subwoofer and powered up via the rocker switch.
- 10 **Polarity** – Reverses the polarity of the subwoofer relative to the two-way Milan loudspeakers connected to the thru outputs.
- 11 **Level Control** – Rotary level control which attenuates the input signal level of the subwoofer and (line) from $-\infty$ (MIN) to +43 dB (MAX).
- 12 **Boost Freq** – Selects the centre frequency at which the boost is applied, and is continuously variable from 40 Hz to 90 Hz.

Milan Series Getting Started

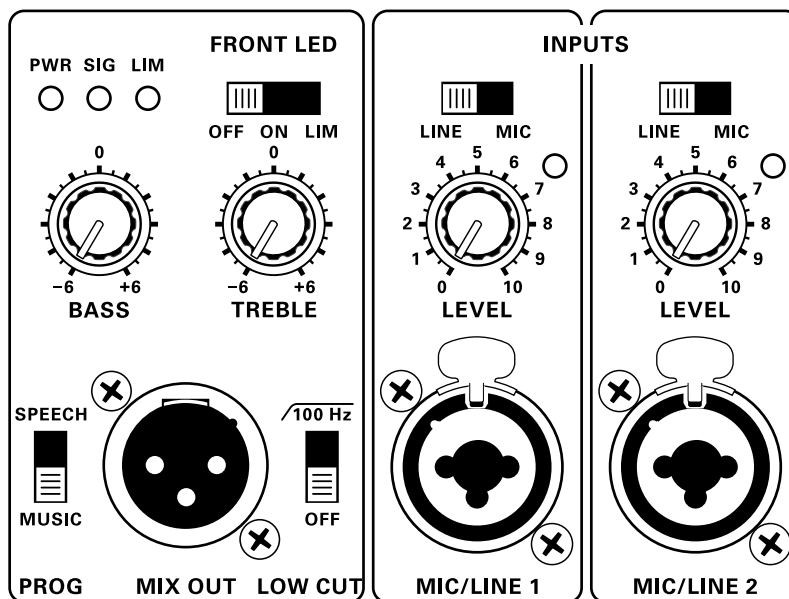

Milan M10, M12 and M15

- 1** Turn the level controls fully anticlockwise (zero) on both input channels.
- 2** Set the **BASS** and **TREBLE** tone controls to their centre position (no boost or cut).
- 3** Connect your signal sources (mixing console, keyboard, microphone, acoustic guitar) to the appropriate input connectors and select **MIC** or **LINE** as appropriate for that source.
- 4** If the loudspeaker is to be used as a floor monitor, or for use with subwoofers, set the **LOW CUT** switch to the '100 Hz' position (up); otherwise select the 'OFF' position (down).
- 5** Switch on the mixer or other source and make sure the output faders or master output level controls are turned fully down.

- 6** Connect the AC mains cable to the Milan loudspeaker and turn on the mains switch. The blue **PWR LED** will illuminate to indicate that mains power is connected.
- 7** Increase the output level of the signal source to a normal operating level.
- 8** Slowly turn up the Milan loudspeaker's level control(s) until a suitable volume level is reached. The **SIG LED** illuminates green to indicate signal present. If the input signal is too high the **CLIP LED** will light and the signal level from the source or mixer must be reduced. The **LIM LED** flashes red when the system is limiting although it is normal for the **LIM LED** to flash occasionally.

- 9** Apply equalisation, if necessary, using the **BASS** and **TREBLE** controls. Cut bass to tame boomy frequencies in the room, and add a little treble to help vocal intelligibility.
- 10** When shutting down the Milan system, first turn down the input level controls, then switch off the mains power before turning off the mixer or signal source.

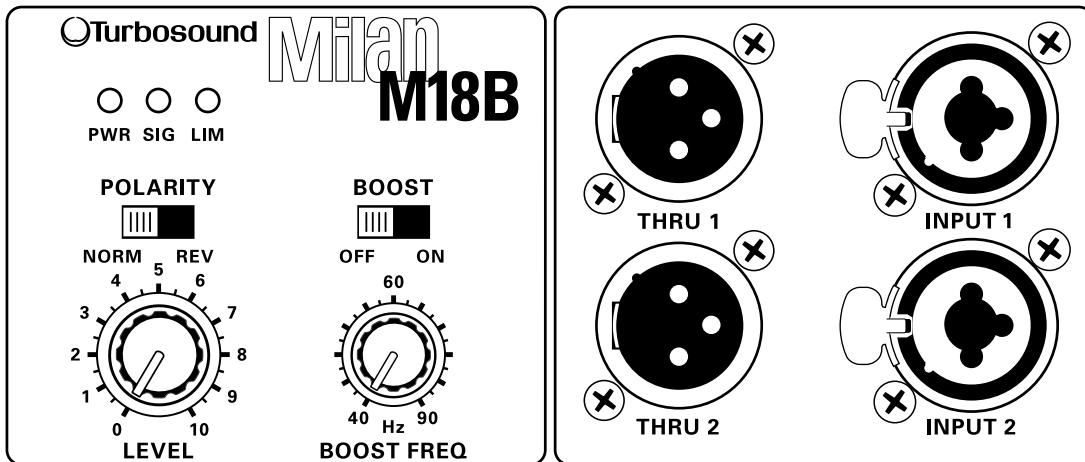

Milan M15B and M18B

- 1** Turn the **LEVEL** control fully anticlockwise (zero).
- 2** Connect the left and right outputs from your mixing console to the appropriate input connectors.
- 3** Switch on the mixing console and make sure the output faders or master output level controls are turned fully down.
- 4** Connect the AC mains cable to the Milan subwoofer and turn on the mains switch. The blue **PWR** LED will illuminate to indicate that mains power is connected.
- 5** Increase the output level of the signal source to a normal operating level.
- 6** Slowly turn up the Milan subwoofer's **LEVEL** control until a suitable volume level and balance with the Milan mid/high loudspeaker is reached. The **SIG** LED illuminates green to indicate signal present. The **LIM** LED flashes red when the system is limiting although it is normal for the **LIM** LED to flash occasionally.
- 7** Set the **POLARITY** switch to **NORM** if the Milan mid/high speakers and subwoofers are physically aligned (e.g., pole mounting). You may set the **POLARITY** switch to **REV** if the Milan mid/high speakers are not physically aligned with the subwoofer (e.g., above or behind) and/or you notice phase cancellation in the sound.
- 8** If additional bass response is required the **BOOST** switch provides +6 dB of lift centred at the frequency selected using the **BOOST FREQ** control.
- 9** When shutting down the Milan system, first turn down the input level controls, then switch off the mains power before turning off the mixer or signal source.

Milan Series Getting Started

Using Milan Loudspeakers with Subwoofers

1. Connect the full range signal from the mixer first to the subwoofer and then run a link from the subwoofer to the Milan loudspeaker.
2. Move the LOW CUT switch on the Milan speaker to the 100 Hz (up) position to avoid overlap with the subwoofer's frequency range.



LOW CUT

Using Milan as a Floor Monitor

1. Activate the LOW CUT switch to prevent boominess from proximity with the floor.



LOW CUT

2. Rotate the BASS CONTROL knob counter-clockwise if vocals require further intelligibility.



NOTE: If drums appear in the monitor mix, EQ the kick drum sparingly in the bass frequencies, preferably by cutting rather than boosting.



WARNING! Make sure that any speaker stands you use are capable of taking the weight of the loudspeaker, and that stands are placed on a flat, level and stable surface. Make sure that the legs do not present a trip hazard. Be careful when lifting the speaker onto the stand; check the weight first before lifting and ask someone else to help you if needed.

Milan Series Rigging Instructions

Using the M10 rigging points

Milan loudspeakers come outfitted with M10 reinforced threaded inserts to facilitate aerial suspension.

1. Plan the installation correctly, including loudspeaker orientation and suspension.
2. Identify suitable suspension points in the structure.
3. Purchase suitable forged eyebolts designed for fixed-installation applications.
4. Insert M10 load-rated shoulder eyebolts into the threaded rigging points and tighten.

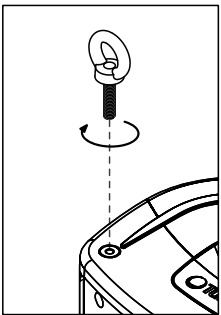

NOTE: The front rigging points should take the majority of the load, while the rear rigging point should be used only for angling the cabinet downwards.

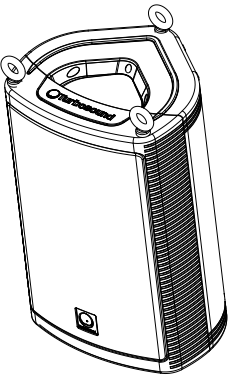

WARNING! Standard consumer bolts are not suitable for these applications and may pose a risk of injury and death. Use only properly forged eyebolts designed for fixed installation applications.



WARNING! For all installations, provide secondary seismic restraint to meet all applicable local codes.

5. When installing the cabinet sideways, pick up from either of the two front eyebolt pairs, and bridle the two rear eyebolt points to provide a single pull-back for adjusting the downward angle.

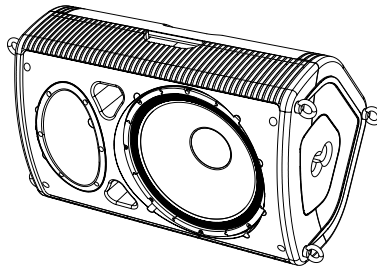

Wall Mounting

The Milan loudspeaker can be conveniently wall mounted using the PB-55 pole mount wall bracket, which simply locates into the pole mount socket in the bottom of the cabinet.

1. Fix the bracket to the wall using suitable fasteners.
2. Mount the loudspeaker onto the pole mount bracket.
3. Rotate and angle the loudspeaker to optimise coverage.
4. Tighten the bracket's locking mechanism to prevent the loudspeaker from being inadvertently removed.

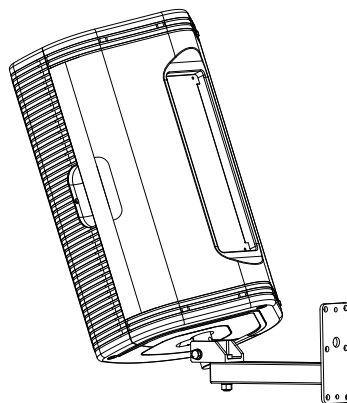

LOUDSPEAKER MOUNTING INSTRUCTIONS – FOR QUALIFIED PERSONNEL ONLY

This loudspeaker system may be permanently installed by qualified personnel, using approved methods and materials. Improper installation can pose serious risk of injury or death. Please read these instructions in their entirety before attempting installation.

Permanent installation may only be attempted by persons licensed and qualified by appropriate authorities governing the installation location. Installers are to employ only original parts, brackets, fasteners and suspension accessories or properly rated and certified components from third parties. Replace any missing parts by contacting the authorized Reseller or Distributor in your region. Clarify all local requirements and obtain necessary approvals and permits before commencing work.

When selecting a location for the loudspeaker to be installed ensure that all mechanical, acoustic and safety considerations are observed. Ensure that the structure is capable of supporting the load and that all hardware is rated accordingly with ample safety factor. Do not suspend loudspeaker over areas of public circulation or where failure of the suspension system can cause bodily or property damage. Inspect suspension hardware regularly to ensure integrity.

Loudspeakers radiate a magnetic field, even when they are not in use. This magnetic field may cause interference with other devices such as computers, magnetic media and certain types of video monitors. Maintain a spacing of 2 meters between the loudspeaker and any such devices to prevent interference.

Music Group, its affiliates and representatives shall not be liable for any property damage or personal injury arising from the improper installation, use or maintenance of this product.

Technical Specifications

Model	M10	M12	M15	M15B	M18B
Components	1 x 10" LF driver 1 x 1" HF driver	1 x 12" LF driver 1 x 1" HF driver	1 x 15" LF driver 1 x 1" HF driver	1 x 15" LF driver	1 x 18" LF driver
Connectors	Mic/Line input: combo jack/female XLR wired pin 2 hot; Mix out: male XLR wired pin 2 hot; IEC mains connector with integrated fuseholder			Input: 2 x female XLR wired pin 2 hot; Thru: 2 x male XLR wired pin 2 hot; IEC mains connector with integrated fuseholder	
Controls					
Controls	Level, Line/Mic, Low Cut, Speech/Music, Bass and Treble, Front LED, Mains on/off			Level, Polarity, Boost, Boost Frequency	
System Data					
Frequency Range	55 Hz–18 kHz ±3 dB 50 Hz–20 kHz -10 dB	50 Hz–18 kHz ±3 dB 45 Hz–20 kHz -10 dB	45 Hz–18 kHz ±3 dB 40 Hz–20 kHz -10 dB	45 Hz–100 Hz ±3 dB 35 Hz–150 Hz -10 dB	40 Hz–100 Hz ±3 dB 30 Hz–150 Hz -10 dB
Dispersion @-6 dB pts	90° H x 60° V	90° H x 60° V	90° H x 60° V	N/A	N/A
Max SPL (peak)	126 dB	128 dB	130 dB	134 dB (half space)	134 dB (half space)
Equalisation	Bass: ±6 dB @ 80 Hz; Treble: ±6 dB @ 12 kHz			N/A	
Boost Frequency	N/A			+6 dB @ 40 Hz–90 Hz, Q=1	
Indicators					
Power LED	Blue			Blue	
Signal LED	Green			Green	
Limit LED	Red			Red	
Clip LED	Red			N/A	
Circuit Protection					
Amplifier Protection	Full short circuit, open circuit, thermal			Full short circuit, thermal, overcurrent, DC	
LF/HF Driver					
Max Output Power	LF: 500 W HF: 100 W	LF: 1000 W HF: 100 W		2200 W	
Audio Inputs					
Input Sensitivity	Mic: -32 dBu; Line: -2 dBu			+4 dBu @ centre position for full rated power	
Input Impedance	Mic: 560 Ω unbalanced, 1 kΩ balanced; Line: 20 kΩ unbalanced, 40 kΩ balanced			10 kΩ unbalanced, 20 kΩ balanced	
Power Supply, Voltage (Fuses)					
USA / Canada	100–120 V~, T 6.3 A H 250 V	100–120 V~, T 8.0 A H 250 V		100–120 V~, T 12 A H 250 V	
UK / Australia / Europe	220–240 V~, T 3.15 A H 250 V	220–240 V~, T 4.0 A H 250 V		220–240 V~, T 6.3 A H 250 V	
China	220–240 V~, T 3.15 A H 250 V	220–240 V~, T 4.0 A H 250 V		220–240 V~, T 6.3 A H 250 V	
Japan	100–120 V~, T 6.3 A H 250 V	100–120 V~, T 8.0 A H 250 V		100–120 V~, T 12 A H 250 V	
Power consumption @ 1/8 max power	80 W	140 W		280 W	
Rigging options	6 x M10 threaded internal rigging points			N/A	
Construction / Dimensions / Weight					
Construction	Injection-moulded polypropylene enclosure. Recessed carrying handles. Integral dual-angle pole mount socket. Powder coated galvanised perforated steel mesh grille with foam backing			Birch plywood, screwed and glued	
Dimensions (H x W x D)	522 x 329 x 294 mm (20.6 x 13 x 11.6")	620 x 394 x 330 mm (24.4 x 15.5 x 13")	719 x 457 x 368 mm (28.3 x 18 x 14.5")	495 x 530 x 480 mm (19.5 x 20.9 x 18.9")	590 x 640 x 530 mm (23.2 x 25.2 x 20.9")
Net weight	13.3 kg (29.3 lbs)	20.5 kg (45.1 lbs)	27.7 kg (60.9 lbs)	37 kg (81.4 lbs)	48 kg (105.6 lbs)

Other important information

EN Important information

- 1. Register online.** Please register your new Music Group equipment right after you purchase it by visiting turbosound.com. Registering your purchase using our simple online form helps us to process your repair claims more quickly and efficiently. Also, read the terms and conditions of our warranty, if applicable.
- 2. Malfunction.** Should your Music Group Authorized Reseller not be located in your vicinity, you may contact the Music Group Authorized Fulfiller for your country listed under “Support” at turbosound.com. Should your country not be listed, please check if your problem can be dealt with by our “Online Support” which may also be found under “Support” at turbosound.com. Alternatively, please submit an online warranty claim at turbosound.com BEFORE returning the product.
- 3. Power Connections.** Before plugging the unit into a power socket, please make sure you are using the correct mains voltage for your particular model. Faulty fuses must be replaced with fuses of the same type and rating without exception.

FEDERAL COMMUNICATIONS COMMISSION COMPLIANCE INFORMATION

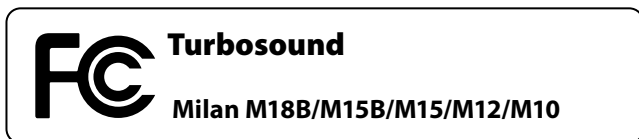

Responsible Party Name: Music Group Research
UK Limited

Address: Klark Industrial Park,
Walter Nash Road,
Kidderminster. Worcestershire. DY11
7HJ. England.

Phone Number: +44 1562 741515

Milan M18B/M15B/M15/M12/M10

complies with the FCC rules as mentioned in the following paragraph:

This equipment has been tested and found to comply with the limits for a Class A digital device, pursuant to Part 15 of the FCC Rules. These limits are designed to provide reasonable protection against harmful interference when the equipment is operated in a commercial environment. This equipment generates, uses, and can radiate radio frequency energy and, if not installed and used in accordance with the instruction manual, may cause harmful interference to radio communications. Operation of this equipment in a residential area is likely to cause harmful interference in which case the user will be required to correct the interference at his own expense.

This equipment complies with Part 15 of the FCC Rules. Operation is subject to the following two conditions:

- (1) This device may not cause harmful interference, and
- (2) This device must accept any interference received, including interference that may cause undesired operation.

Important information:

Changes or modifications to the equipment not expressly approved by Music Group can void the user's authority to use the equipment.