

## Digital I/O Card – TDIF-1 (CD8-TDII)

The TDFI-1 digital I/O card (CD8-TDII) is used to connect TASCAM TDFI-1 modular digital multitrack recorders such as the DA-88 to the 02R.

### Installing the CD8-TDII

The TDFI-1 digital I/O card (CD8-TDII) is a single slot card. For installation instructions, see “Single Slot Cards” on page 175 of the *User’s Guide*.

1. **Connect the TASCAM DA-88 modular digital multitrack recorder to the 02R using the appropriate connectors.**

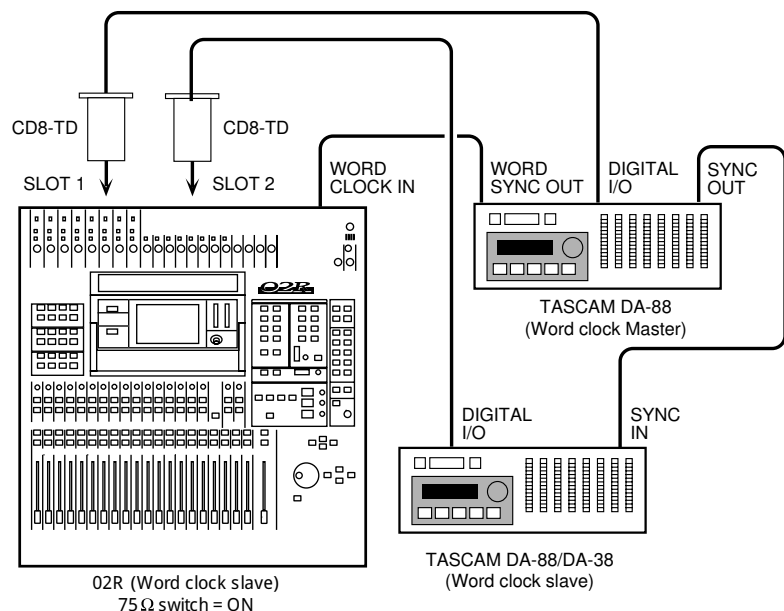

Use the special cable to plug the connector of the CD8-AT to the DIGITAL I/O connector of the TASCAM DA-88 recorder.

If you have installed more than one CD8-TDII in the 02R and have more than one TASCAM DA-88 recorder, connect it in the same manner as the first unit.

2. **The TASCAM DA-88 recorder is equipped with a WORD SYNC OUT connector. Use a BNC cable to plug it into the WORD CLOCK – IN connector on the back of the 02R.**

If you are using more than one TASCAM DA-88 recorder, make the first unit the wordclock master. There are SYNC IN/SYNC OUT connectors on the DA-88 recorders that allow them to run together. DA-38s can not be used as wordclock master, because they do not have a SYNC OUT connector.

## Wordclock Selection

1. Power on your DA-88 modular digital multitrack recorder and then the 02R.

It is always important to observe the correct order for powering up equipment in a studio. Start with the DA-88 and mastering recorders and the signal processors, then the 02R, and finally the monitoring amplifiers and other downstream gear.

2. Press the (DIGITAL I/O) button until the “Word Clock Select” screen appears.

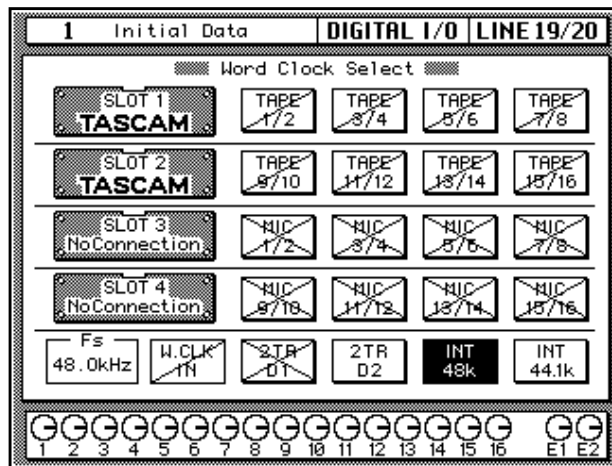

If the card was installed properly, the system software should correctly identify it in the appropriate slot. The TDFI-1 digital I/O card (CD8-TDII) can be installed in any slot. You should install the first two cards in SLOT1 and SLOT2 in order to access the direct out lines.

**Note:** If the W.CLK IN box is not showing a proper wordclock input (no discrepancy between the input and selected wordclock frequencies), check the BNC cable between the WORD SYNC OUT connector on the DA-88 and the WORD CLOCK IN connector on the 02R. Check that the DA-88 is powered on.

3. Use the CURSOR buttons to select the wordclock source.

Use the CURSOR buttons to select the W.CLK IN box and press the [ENTER] button.

4. When you select the wordclock source, the appropriate icon should be inverted in reverse video.

See “Word Clock Select” on page 154 of the *User’s Guide* for further details.

## Word Clock Select

1. Press the (DIGITAL I/O) button.



A DIGITAL I/O display function appears. The “Word Clock Select” screen is the first of many screens in this function.

**Note:** *The 02R always recalls the last function visited (and the screen of that function) even after you turn the power off and back on again.*

You may have to press the (DIGITAL I/O) button repeatedly to get to the “Word Clock Select” screen.

2. Use the CURSOR buttons to select a wordclock source and press the (ENTER) button.

The Digital Recording Console 02R processes audio data at 44.1 kHz or 48 kHz using its internal clock, and can run at any frequency from 32 kHz -6% to 48 kHz +6% when an external wordclock is applied.

### Wordclock

When you connect a number of digital audio devices together, all the devices should synchronize to one device – the wordclock master. The wordclock master generates a sync pulse which allows the other devices connected to it to determine where the start of each digital word is. Although most digital interconnect protocols are self-clocking, it is more reliable to use a dedicated line for your wordclock signal. This is especially important in a multitrack environment where up to eight channels of digital data may be multiplexed on one cable.

When you are using a digital device – such as a DAT mastering recorder or a modular digital multitrack recorder – connected to the 02R, all the digital devices in the system, including the 02R, should synchronize the wordclock being supplied by one master device. If any device does not synchronize to the system wordclock, dropout and/or other noise may occur.

In Section 13, “Installing Options” on page 171 of the *User’s Guide*, there are examples of connecting external digital devices to the 02R and setting the appropriate wordclock selection. Refer to this section for details for each of the optional digital I/O cards.

**Note:** *Wordclock is not required if you use the analog I/O card (CD8-AD) to connect to an analog multitrack recorder.*

### Display Screen

Shown below is the first DIGITAL I/O display function – the Word Clock Select screen:

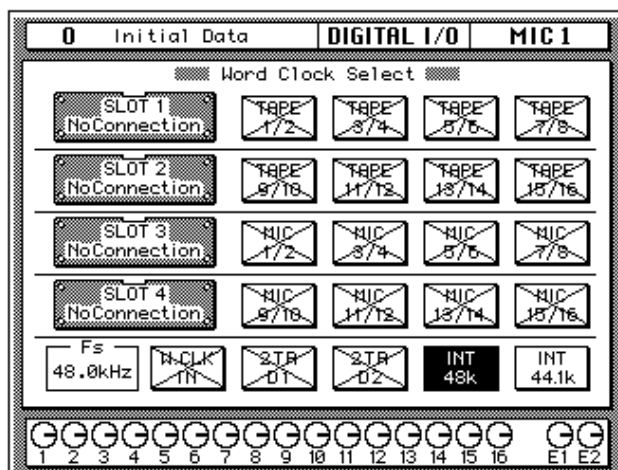

The left side of the display is a list of the cards in the four option slots of the 02R. The indication varies depending on the type of optional card being used:

- Cascade (CD8-CS)
- ADAT (CD8-AT)
- TDIF-1 (CD8-TDII)
- AES/EBU (CD8-AE/CD8-AE-S)
- YAMAHA (CD8-Y)
- Analog AD/DA (CD8-AD)
- No Connection

Beside each optional slot indicator is a row of four boxes defining the connections to the card inserted in the corresponding slot.

---

**Note:** *When a cascade card is inserted in any slot, the boxes defining the connections remain on the screen. However, you cannot select any of these items.*

---

Across the bottom of the display are boxes for the external wordclock (W.CLK IN), the digital inputs (2TR D1 and 2TR D2), and the internal wordclock (INT 48k and INT 44.1k). To the left of the boxes are the wordclock indicators.

There is also an indicator – inside the “Fs” box – that shows the current wordclock frequency or status.

### Wordclock indicators



No wordclock input.



Wordclock input. However, the input wordclock frequency is different from that of the selected wordclock.



Wordclock input. No discrepancy between the input and selected wordclock frequencies.



Wordclock input is selected. The 02R is synchronized to the input wordclock frequency.



The wordclock input is selected, but the wordclock signal is inappropriate.



# 02R with One DA-88

This application shows how the 02R can be used with a Tascam DA-88 to create a 24-input, 8-track digital recording system. The eight digital tape returns and 24 Mic/Line inputs provide up to 32 inputs at mixdown. In addition, the 02R's built-in automation and scene memory systems provide both dynamic and static mix automation referenced to timecode.

## Connections

- The Tascam (CD8-TD) card must be screwed securely in place. Do not leave the screws out after installation as the card will not be grounded correctly.
- The Tascam digital audio cable (PW-88DL) carries the eight tape sends and eight tape returns.
- The DA-88 is connected to Slot **1** of the 02R. These tape inputs correspond to tracks one through eight.
- The optional SY-88 Sync Board is required. The DA-88 has a dedicated timecode track and can output SMPTE timecode or MTC. In addition, a timecode offset can be specified on the DA-88, so the 02R automix start time can be adjusted. The DA-88 also has the ability to re-stripe the timecode track.
- The 75 ohm wordclock termination switch on the back of the 02R is set to ON.

## 02R Wordclock Setup

On the DIGITAL I/O menu, the wordclock source should be set to W.CLK.

## DA-88 Wordclock Setup

The DA-88 works as wordclock master. Wordclock is fed to the 02R using a BNC to BNC cable. The sampling rate is set when the DA-88 tape is formatted. This can be either 48 kHz or 44.1 kHz. After formatting, the sampling rate is determined by the formatted tape.

## Notes

- The DA-88 must be powered up even when it is not being used. Failure to do so may cause an intermittent pumping noise on the 02R.
- On the DA-88 rear panel, set the MACHINE ID to 0.
- The optional **Tascam SY-88 Sync Board** must be installed to use SMPTE timecode and MTC. This is available from Tascam.
- The rear panel of the SY-88 Sync Board has a DIP switch labeled MODE. Set DIP switches 2 and 5 to ON (O). Set internal switch 8 on the SY-88 board marked S2 to ON.
- To use the MTC function, the SY-88 firmware must be version 3.08 or higher.
- On the Tascam (CD8-TD) card there is a DIP switch that should be set to 16-bit. This is the initial setting, but you should confirm it. This switch is for use with Tascam High-Bit recording applications.
- Tascam 25-pin digital audio cables PW-88DL (5 m) and PW-88D (1 m) are available from Tascam.

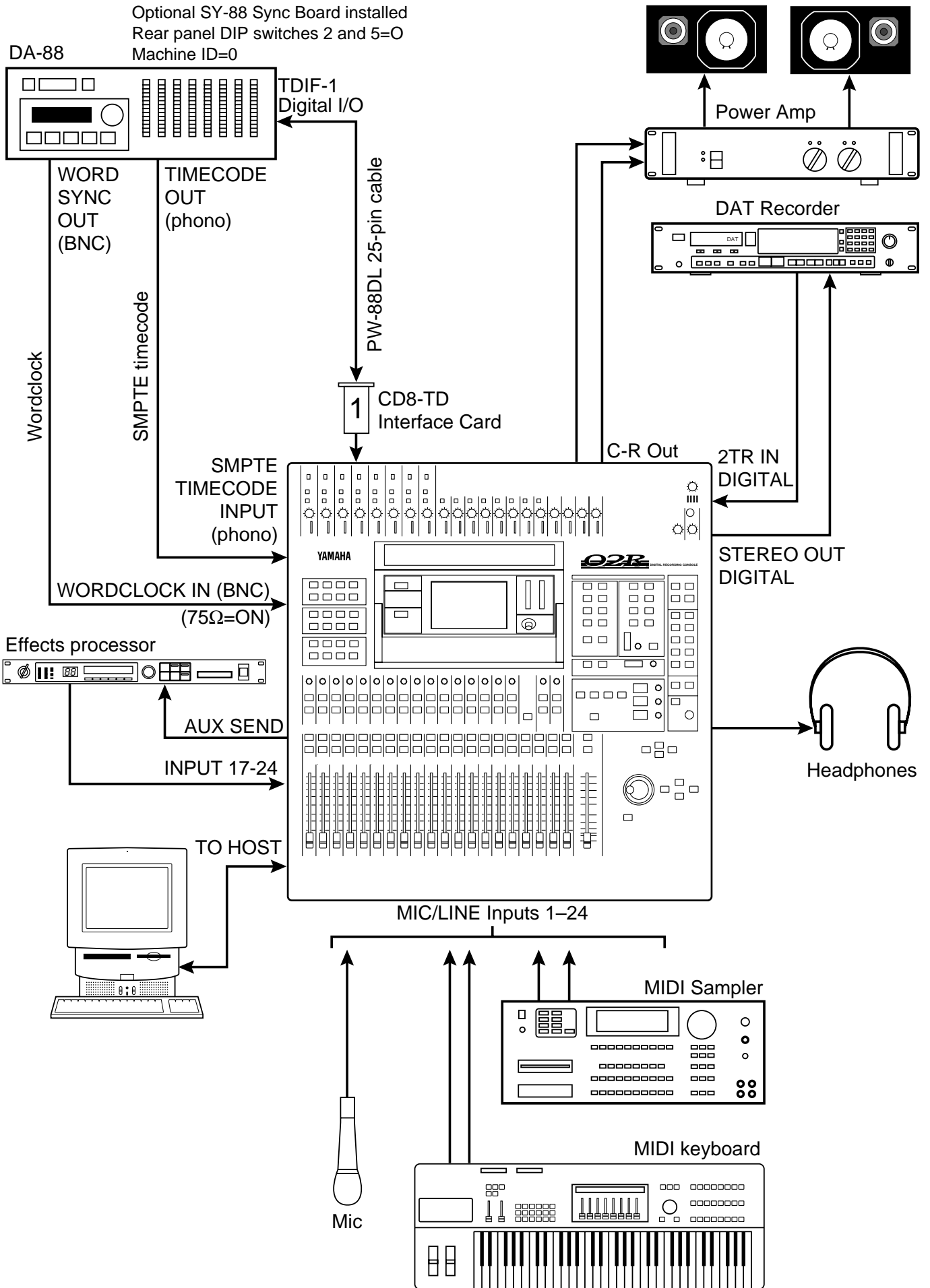

Figure 9 O2R with One DA-88

# 02R with Two DA-88s

This application shows how the 02R can be used with two Tascam DA-88s to create a 24-input, 16-track digital recording system. The 16 tape returns and 24 Mic/Line inputs provide up to 40 inputs at mixdown. In addition, the 02R's built-in automation and scene memory systems provide both dynamic and static mix automation referenced to timecode.

## Connections

- The Tascam (CD8-TD) cards must be screwed securely in place. Do not leave the screws out after installation as the cards will not be grounded correctly.
- The Tascam digital audio cables (PW-88DL) carry the eight tape sends and returns.
- DA-88–A is connected to Slot **1** of the 02R. These tape inputs correspond to tracks one through eight. DA-88–B is connected to Slot **2** of the 02R. These tape inputs correspond to tracks nine through sixteen.
- The optional SY-88 Sync Board is required for DA-88–A. This enables the dedicated timecode track, which can be re-striped at anytime, and provides SMPTE timecode and MTC outputs. A timecode offset can be specified on DA-88–A, so the 02R automix start time can be adjusted.

## 02R Wordclock Setup

On the DIGITAL I/O menu, the wordclock source should be set to W.CLK.

## DA-88 Wordclock Setup

DA-88–A works as wordclock master. Wordclock is fed to the 02R using a BNC to BNC cable, and to the DA-88–B using a PW-88S 15-pin sync cable. The sampling rate is set when the DA-88 tapes are formatted. This can be either 48 kHz or 44.1 kHz. After formatting, the sampling rate is determined by the formatted tape.

## Notes

- The DA-88s must be powered up even when they are not being used. Failure to do so may cause an intermittent pumping noise on the 02R.
- DA-88–A is set to MACHINE ID 0. DA-88–B is set to MACHINE ID 1. Since DA-88–A works as Control Master, it should be used for synchronized transport and locate operations.
- The optional **Tascam SY-88 Sync Board** must be installed in DA-88–A to use SMPTE timecode and MTC. This is available from Tascam. DA-88–B does not require the SY-88 Sync Board nor does its tape have to be striped with timecode. It is synchronized to DA-88–A via the PW-88S 15-pin sync cable.
- The terminator bundled with the PW-88S sync cable should be connected to the SYNC OUT on DA-88–B to ensure reliable synchronization.
- The rear panel of the SY-88 Sync Board has a DIP switch labeled MODE. Set DIP switches 2 and 5 to ON (O). Set internal switch 8 on the SY-88 board marked S2 to ON.
- To use the MTC function, the SY-88 firmware must be version 3.08 or higher.
- On the Tascam (CD8-TD) card there is a DIP switch that should be set to 16-bit. This is the initial setting, but you should confirm it. This switch is for use with Tascam High-Bit recording applications.
- Tascam 25-pin digital audio cables PW-88DL (5 m) and PW-88D (1 m), and the 15-pin PW-88S sync cable are available from Tascam.

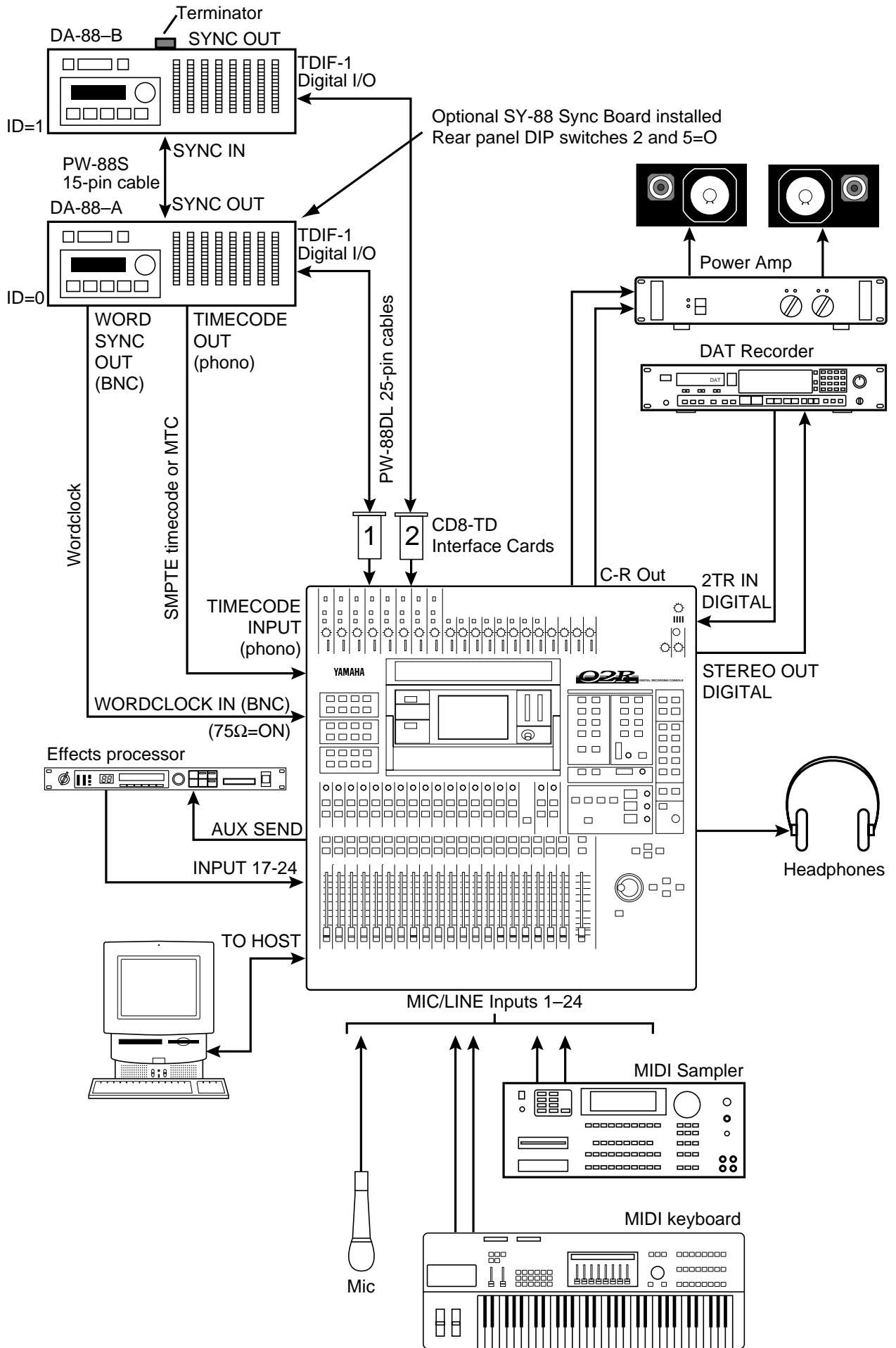

Figure 10 O2R with Two DA-88s



# 02R with Four DA-88s

This application shows how the 02R can be used with four Tascam DA-88s to create a 24-input, 32-track digital recording system, providing 32-track digital mixdown. In addition, the 02R's built-in automation and scene memory systems provide both dynamic and static mix automation referenced to timecode.

## Connections

- The Tascam (CD8-TD) cards must be screwed securely in place. Do not leave the screws out after installation as the cards will not be grounded correctly.
- DA-88–A is connected to Slot **1** of the 02R and the tape inputs correspond to tracks one through eight (Tape In 1–8). DA-88–B is connected to Slot **2** of the 02R and the tape inputs correspond to tracks nine through sixteen (Tape In 9–16). DA-88–C is connected to Slot **3** of the 02R and the tape inputs correspond to tracks 17 through 24 (Line In 1–8). DA-88–D is connected to Slot **4** of the 02R and the tape inputs correspond to tracks 25 through 32 (Line In 9–16).
- The optional SY-88 Sync Board is required for DA-88–A. This enables the dedicated timecode track, which can be re-striped at anytime, and provides SMPTE timecode and MTC outputs. A timecode offset can be specified on DA-88–A.

## 02R Wordclock Setup

On the DIGITAL I/O menu, the wordclock source should be set to W.CLK.

## DA-88 Wordclock Setup

DA-88–A works as wordclock master. Wordclock is fed to the 02R using a BNC to BNC cable, and to the other DA-88s using PW-88S 15-pin sync cables. The sampling rate is set when the DA-88 tapes are formatted. This can be either 48 kHz or 44.1 kHz. After formatting, the sampling rate is determined by the formatted tape.

## Notes

- The DA-88s must be powered up even when they are not being used. Failure to do so may cause an intermittent pumping noise on the 02R.
- DA-88–A is set to MACHINE ID 0, DA-88–B to MACHINE ID 1, DA-88–C to MACHINE ID 2, and DA-88–D to MACHINE ID 3. Since DA-88–A works as the Control Master, it should be used for synchronized transport and locate operations.
- The optional Tascam SY-88 Sync Board must be installed in DA-88–A to use SMPTE timecode and MTC. This is available from Tascam. The other DA-88s do not require SY-88 Sync Boards and their tapes do not have to be striped with timecode. They are synchronized to DA-88–A via the PW-88S 15-pin sync cables.
- The terminator bundled with a PW-88S sync cable should be connected to the SYNC OUT on DA-88–D to ensure reliable synchronization.
- The rear panel of the SY-88 Sync Board has a DIP switch labeled MODE. Set DIP switches 2 and 5 to ON (O). Set internal switch 8 on the SY-88 board marked S2 to ON.
- To use the MTC function, the SY-88 firmware must be version 3.08 or higher.
- On the Tascam (CD8-TD) card there is a DIP switch that should be set to 16-bit. This is the initial setting, but you should confirm it. This switch is for use with Tascam High-Bit recording applications.
- Tascam 25-pin digital audio cables PW-88DL (5 m) and PW-88D (1 m), and the 15-pin PW-88S sync cable are available from Tascam.

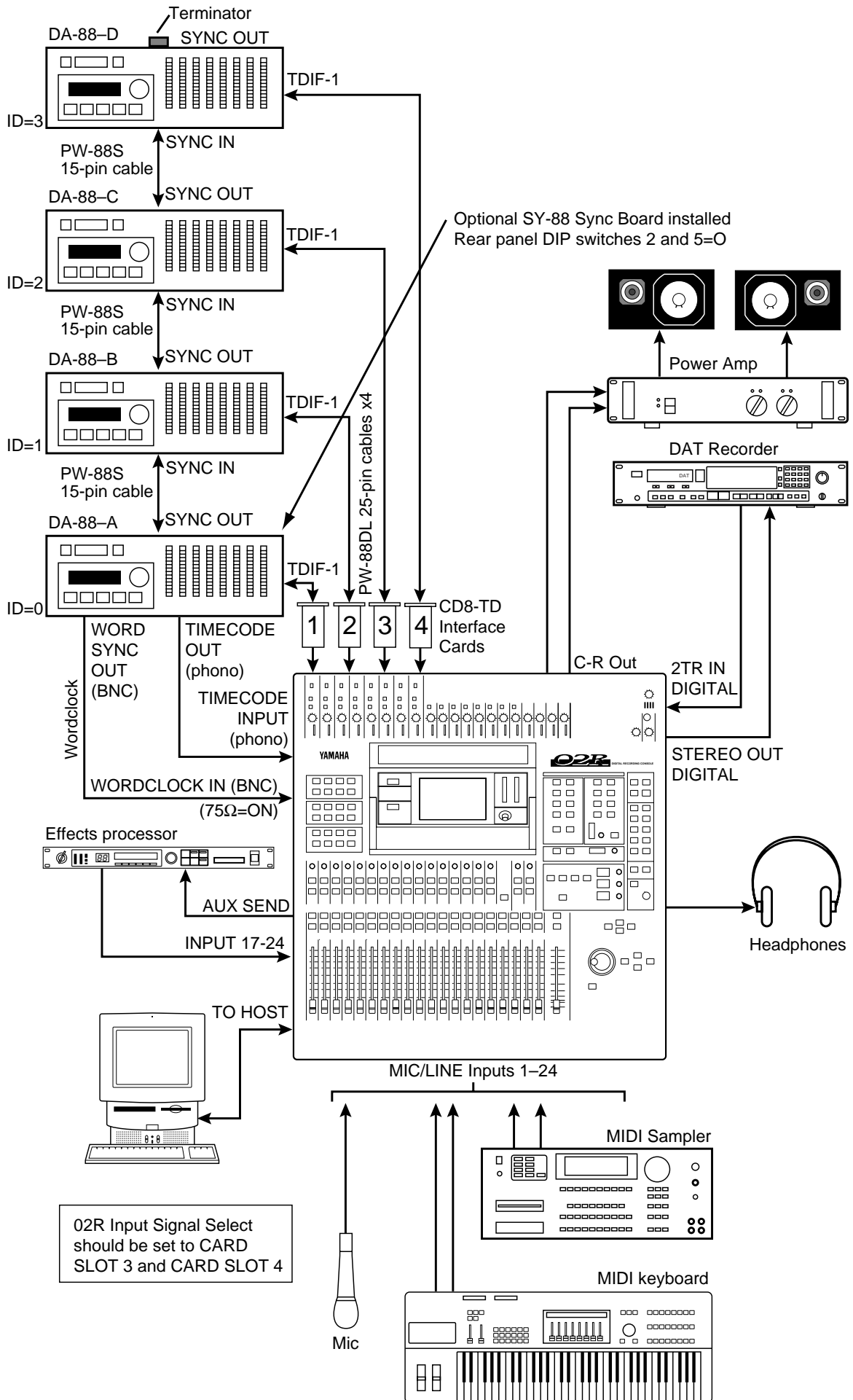

Figure 11 O2R with Four DA-88s

# Two 02Rs with Four DA-88s

This application shows how two 02Rs can be used with four Tascam DA-88s to create a 48-input, 32-track digital recording system. The 32 digital tape returns and 48 Mic/Line inputs provide up to 80 inputs at mixdown.

The two 02Rs are cascaded together using a 25-pin straight cable and two CD8-CS Cascade cards, which are installed in Slot **3** of each 02R (could be Slot **4**). The cascade connection carries the eight buses, any four of the eight AUX buses, Stereo bus, and Solo bus. This allows both consoles to work together as one large 80-input mixing console. The master section of 02R-B is used for monitoring and two-track operations. The studio monitors and two-track recording equipment are also connected to this 02R.

## Connections

- The Tascam (CD8-TD) cards must be screwed securely in place. Do not leave the screws out after installation as the cards will not be grounded correctly.
- DA-88-A is connected to Slot **1** of 02R-A and the tape inputs correspond to tracks one through eight (Tape In 1-8). DA-88-B is connected to Slot **2** of 02R-A and the tape inputs correspond to tracks nine through sixteen (Tape In 9-16). DA-88-C is connected to Slot **1** of 02R-B and the tape inputs correspond to tracks 17 through 24 (Tape In 1-8). DA-88-D is connected to Slot **2** of 02R-B and the tape inputs correspond to tracks 25 through 32 (Tape In 9-16). PW-88DL cables are available from Tascam.
- The optional SY-88 Sync Board is required for DA-88-A. This enables the dedicated timecode track, which can be re-striped at anytime, and provides SMPTE timecode and MTC outputs. A timecode offset can be specified on DA-88-A.

## 02R Wordclock Setup

On the DIGITAL I/O menu, the wordclock source should be set to W.CLK.

## DA-88 Wordclock Setup

DA-88-A works as wordclock master. Wordclock is fed to the 02R using a BNC to BNC cable, and to the other DA-88s using PW-88S 15-pin sync cables, available from Tascam. The sampling rate is set when the DA-88 tapes are formatted. This can be either 48 kHz or 44.1 kHz. After formatting, the sampling rate is determined by the formatted tape.

## Notes

- The DA-88s must be powered up even when they are not being used. Failure to do so may cause an intermittent pumping noise on the 02R.
- DA-88-A is set to MACHINE ID to 0, DA-88-B to MACHINE ID to 1, DA-88-C to MACHINE ID 2, and DA-88-D to MACHINE ID 3. Since DA-88-A works as the Control Master, it should be used for synchronized transport and locate operations.
- The optional Tascam SY-88 Sync Board must be installed in DA-88-A to use SMPTE timecode and MTC. This is available from Tascam. The other DA-88s do not require SY-88 Sync Boards and their tapes do not have to be striped with timecode. They are synchronized to DA-88-A via the PW-88S 15-pin sync cables.
- The terminator bundled with a PW-88S sync cable should be connected to the SYNC OUT on DA-88-D to ensure reliable synchronization.
- The rear panel of the SY-88 Sync Board has a DIP switch labeled MODE. Set DIP switches 2 and 5 to ON (O). Set internal switch 8 on the SY-88 board marked S2 to ON.
- To use the MTC function, the SY-88 firmware must be version 3.08 or higher.

- On the Tascam (CD8-TD) card there is a DIP switch that should be set to 16-bit. This is the initial setting, but you should confirm it. This switch is for use with Tascam High-Bit recording applications.
- The rear of the Cascade (CD8-CS) card has an IN/OUT switch. For 02R–A this must be set to OUT. On 02R–B it must be set to IN.
- The optional CD8-CS kit contains two CD8-CS cards and one 25-pin straight cable.

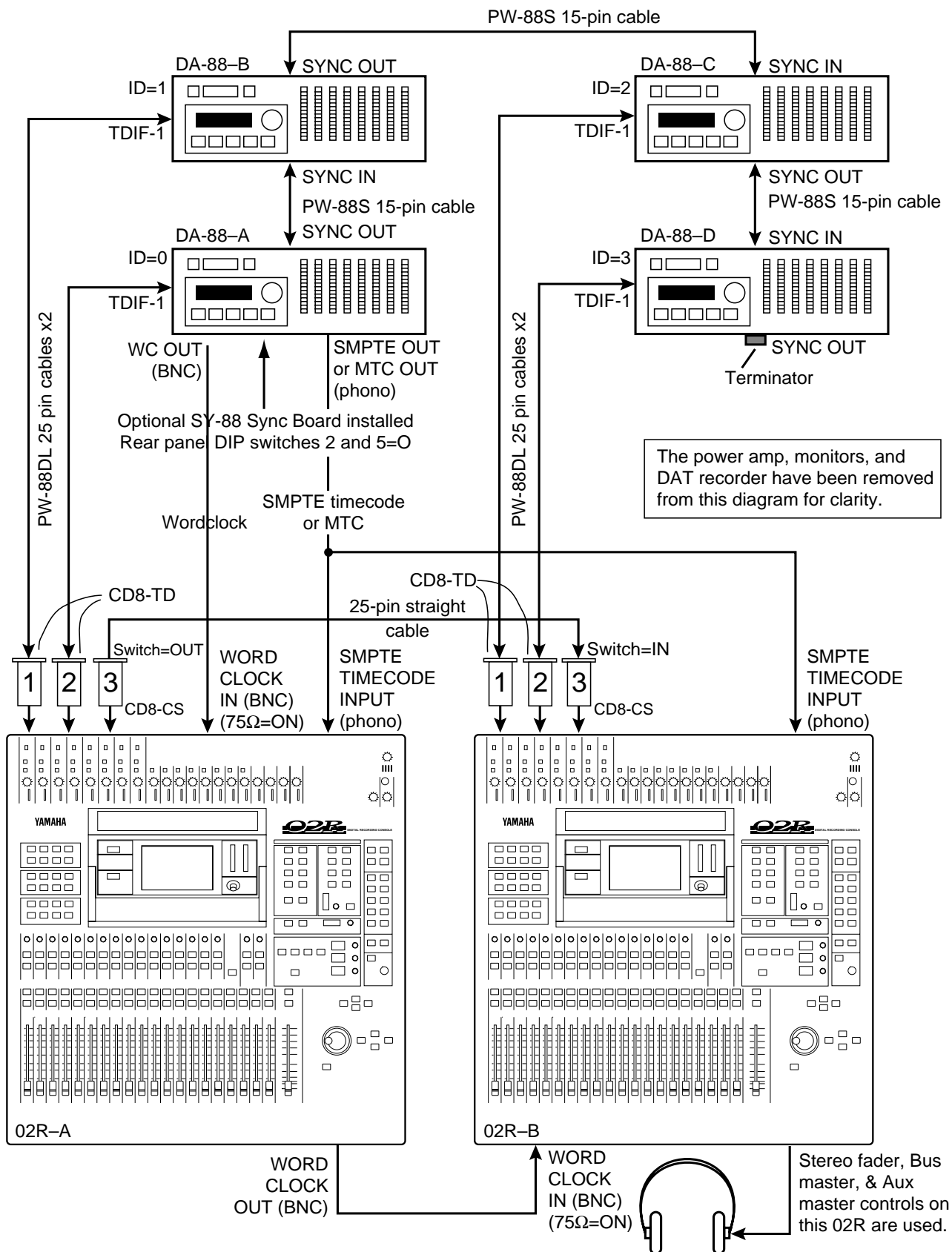

Figure 12 Two 02Rs with Four DA-88s