

YAMAHA **S250X**
COMPACT PA SPEAKER SYSTEM



Compact and Powerful

The Yamaha S250X PA Speaker System is a remarkable development in sound reinforcement speaker design. The S250X enclosure is a mere 21-7/8" wide by 17-1/2" high by 10" deep, yet it will happily accept 250 watts continuous program input power and deliver 97 dB/w/m sound pressure level in return. Moreover, its exceptionally broad, even dispersion characteristics at all frequencies make it easy to achieve complete audience coverage in just about any situation. All this has been made possible by a rather unique 2-way bass-reflex design incorporating a newly developed wide-dispersion horn tweeter and dual bass drivers featuring durable-but-sensitive

carbon-fiber cones—a Yamaha original. The sound is also totally unique for a speaker system of this size: superb definition, transparency and balance through the operational frequency range. The S250X is virtually unlimited in terms of application possibilities, too. Ideal for music or voice reproduction, it can be stand-mounted, stacked, suspended, wall mounted or used as a foldback system. Overall, the S250X offers the sound, performance, power and coverage of much larger and more complex PA speaker systems in an extremely roadable, easy-to-handle format.

Improved HF Compression Driver and Horn

For this system Yamaha designed a special, perfectly matched compression driver and horn system. The driver itself delivers exceptionally fine definition, especially in the mid-high frequency range, and the horn offers unusually broad high-frequency dispersion so that complete audience coverage can be achieved with a minimum number of speakers. Further, even sound pressure level has been achieved over the full frequency range, obviating the need for equalization. This also means that the S250X does not demand as much power from the amplifiers as speaker systems requiring equalization.

Dual Carbon Cone Woofers

The S250X incorporates dual high-performance 8" carbon-cone woofers that deliver full, dynamic bass response that is also tight and clean. These woofers won't show a trace of muddiness even with

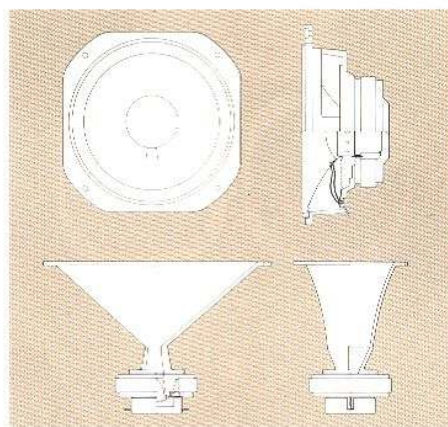

sharp percussive sources. Power linearity is also superb so you get the same high performance across a broad dynamic range. The unique carbon-fiber cone material also means that these speakers are highly resistant to moisture and humidity, exhibiting the same fine performance in virtually any environment. Of course, this makes the S250X ideal for PA applications.

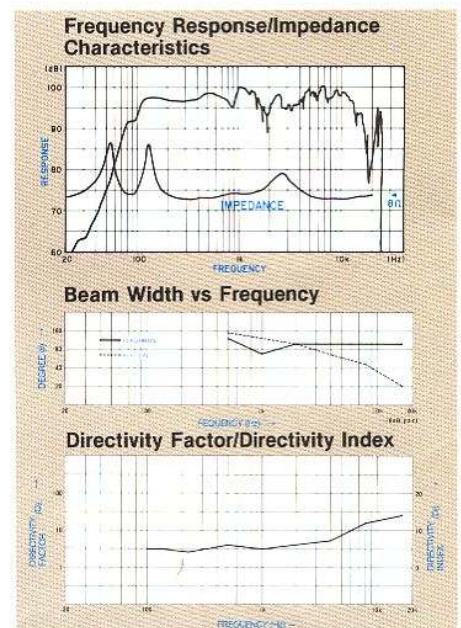

A combination of Douglas fir veneer panels and a high-density particle board baffle aid in producing smooth, natural overall response. Of course, durability has been maximized so the S250X will stand up under the rigours of hard PA use.



State-Of-the-Art Enclosure Design

The S250X's compact, elegant bass reflex enclosure has been designed and constructed with the utmost care. Enclosure volume, panel thickness, bass-reflex port design and positioning, reinforcement—all have been precisely determined through a combination of Yamaha experience, expertise in acoustics, and detailed computer analysis. The modal response of the enclosure has also been optimized through sophisticated computer modelling.

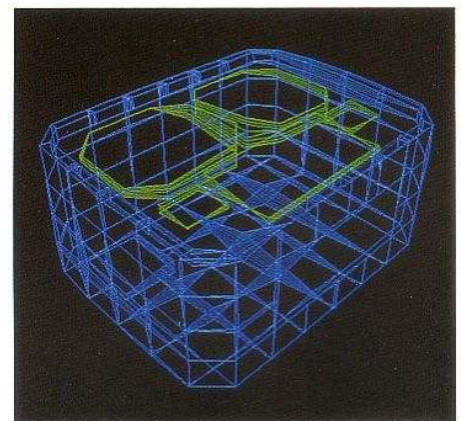

Broad, Even Coverage

Uncompromised Selection of Materials and Parts

A major factor contributing to the excellent all-round performance of the S250X—despite its compact dimensions—is a no-compromise approach to selection of parts and materials. The unique carbon-fiber woofer cones and newly designed compression driver/horn combination are excellent examples. Others include special copper pole caps in the woofers that effectively minimize distortion permitting precise bass response. New, specially selected materials have also been used in the voice coils and edge dampers to provide improved heat and vibration resistance. The highest quality parts have also been employed in the critical crossover network, and wiring is all pure oxygen-free copper for the highest signal transmission accuracy.

Careful Attention to Design Details

The S250X delivers more than just great sound performance. Every detail has been



designed to make it the easiest-to-use speaker available. Handle placement, for example, facilitates carrying, and the corners of the grip hole have been rounded for comfort. The connectors are recessed into the rear panel eliminating the problem of connector breakage, and the speakers can be set right up against a wall where space is limited. Further, the supplied connectors can be replaced with XLR types by simply removing the connector plate. The enclosures have also been designed for maximum stability when stacked.

Application Examples

The S250X is a remarkable versatile PA speaker system. The following are just a few examples of possible applications.

1. House PA Stacks

Specially designed corner protectors help to provide maximum stack stability. BSS-250 stack support adaptors can also be connected to the sockets on either side of the S250X enclosures for an absolutely immovable stack. Use as many S250Xs as your system requires.

2. Stand Mounting

The S250X can also be mounted on commercially available stands. This setup is ideal for outdoor use, and since the speaker is raised from the floor surface it helps deliver optimum sound quality indoors.

3. Ceiling Suspension

4. Wall Mounting

Especially in small clubs, halls or discos where floor space is at a premium, ceiling suspension or wall mounting are ideal. The BCS-250 bracket is available for ceiling suspension, and the BWS-250 bracket is ideal for wall mounting.

5. Foldback

The S250X is also ideal for use as an on-stage floor monitor speaker. The BFS-250 adaptor permits the speaker to be set at the optimum monitoring angle.



1



2

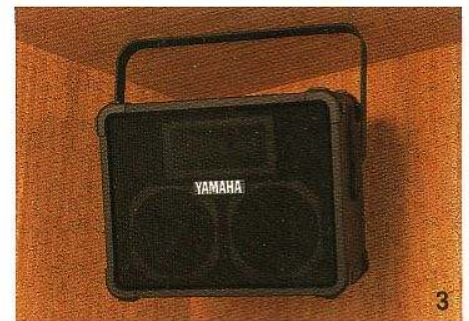

3



4



5

SPECIFICATIONS

Speaker Units	
Woofers:	20 cm (8") carbon-fiber Cone Woofer JA2113 (16 Ω) × 2
Tweeter:	Compression driver + horn JA3202 (8 Ω)
Enclosure:	34 ℓ Bass Reflex Type
System Impedance:	8 ohms nominal
Rated Input:	Program 250 W Max. 500 W
Frequency Response:	65 Hz to 17 kHz
Sound Pressure Level:	97 dB 1 W, 1 m (3.3 ft.)
Crossover Frequency:	2.5 kHz
Inputs:	1/4" phone jack × 2
Dimensions (W × H × D):	556 × 446 × 257 mm (21-7/8" × 17-1/2" × 10")
Weight:	19.2 kg (42.3 lbs)

Specifications subject to change without notice.

OPTIONAL ACCESSORIES

Stacking Support Adaptor BSS-250
Wall Mounting Bracket BWS-250
Ceiling Bracket BCS-250
Foldback Adaptor BFS-250

DIMENSIONS

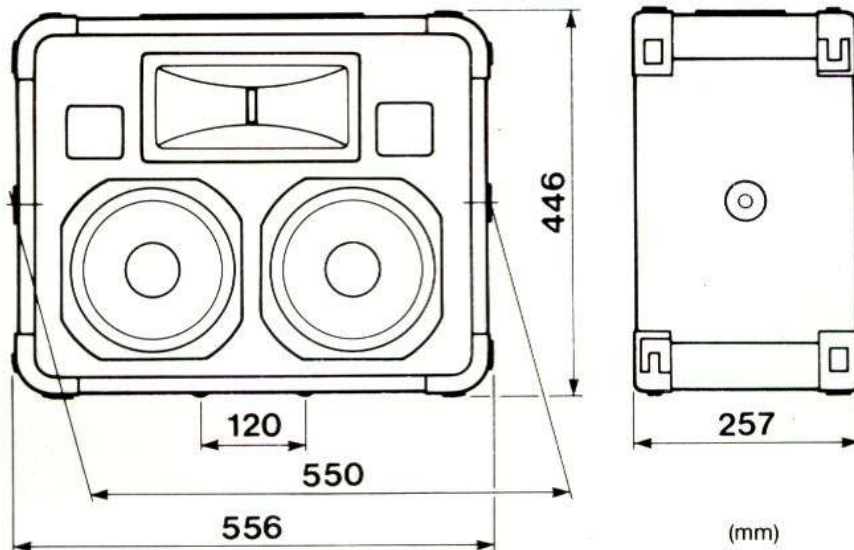

For details please contact:

YAMAHA
YAMAHA CORPORATION
P.O.Box 1, Hamamatsu, Japan